

Original MINI Accessories. Installation Instructions.



Additional high-beam headlights retrofit

MINI ONE (R55, R56, R57)

MINI COOPER (R55, R56, R57)

MINI COOPER D (R55, R56, R57)

MINI COOPER S (R55, R56, R57)

MINI COOPER S JOHN COOPER WORKS (R55, R56, R57)

MINI COUNTRYMAN (R60)

Retrofit kit No.:	63 12 0 417 885	Additional high-beam headlights retrofit kit, black
	63 21 0 420 292	Additional high-beam headlights retrofit kit, chrome
	63 13 0 422 704	Holder and grille Cooper S
	63 13 0 422 706	Holder and grille Cooper S with Aerodynamics package SZ
	63 13 0 422 707	Holder and grille Cooper chrome
	63 13 0 422 708	Holder and grille Cooper with Aerodynamics package SZ
	63 13 0 427 567	Holder and grille MINI Diesel
	63 13 0 427 568	Holder and grille MINI One
	63 13 0 427 569	Holder and grille Cooper with Aerodynamics package SAZ
	63 13 2 186 303	Holder and grille Countryman One
	63 13 2 186 304	Holder and grille Countryman Cooper
	63 13 2 186 305	Holder and grille Countryman One/Cooper chrome
	63 13 2 186 306	Holder and grille Countryman Cooper S
	51 45 2 186 312	Trim with button MINI Countryman

Installation time

The installation time is **approx. 1.75 hours**. This may vary depending on the condition of the car and the equipment in it.

Important information

These installation instructions are primarily designed for use within the MINI dealership organisation and by authorised MINI service companies.

In any event the target group for these installation instructions is specialist personnel trained on MINI cars with the appropriate specialist knowledge.

All work must be completed using the latest MINI repair manuals, wiring diagrams, servicing manuals and work instructions, in a rational order, using the prescribed tools (special tools) and observing current health and safety regulations.

If you experience installation or function problems, limit troubleshooting to approx. 0.5 hours for mechanical or 1.0 hour for electrical work.

In order to reduce costs and avoid any additional expense, send a query immediately to the Technical Parts Support via the Aftersales Assistance Portal (ASAP).

Specify the following information:

- Chassis number,
- part number of the retrofit kit,
- a precise description of the problem,
- work steps already carried out.

Pictograms



Denotes instructions that draw your attention to dangers.



Denotes instructions that draw your attention to special features.

◀ Denotes the end of the instruction or other text.

Print out the “Customer information for the additional high-beam headlights” section at the end of the installation instructions and give it to the customer.

Do not archive the hard copy of these installation instructions since daily updates are made via ASAP!

Installation information

The central radiator grille must be removed and replaced with the new central radiator grille **C** with the cut-out for the holder.

On cars with the central radiator grille in the honeycomb or slatted design without chrome, no conversion work is required.

On cars with the central radiator grille in the slatted design with chrome, the chrome trims must be put into the new central radiator grille **C**.

All pictures show LHD cars; proceed accordingly on RHD cars.

Ensure that the cables and/or lines are not kinked or damaged as you install them in the car. Costs incurred as a result of this will not be reimbursed by BMW AG.

Additional cables/lines that you install must be secured with cable ties.

Ordering instructions

The following parts are not supplied in the retrofit kit and must be ordered separately (see EPC for part number and details).

- Holder and grille (contains the central radiator grille **C**, left holder **E** and right holder **F**)
- Knee protection on the driver's side **Q** (R55, R56, R57 cars only)
- Trim on the driver's side **T** (R60 cars only)

Special tools required

None

Table of contents

Section	Page
1. Parts list	4
2. Preparatory work	5
3. Connection diagram	6
4. Installation and cabling diagram	7
5. Installing and connecting the wiring harness	8
6. Installing the additional high-beam headlights holder	11
7. Converting the radiator grille and installing the additional high-beam headlights	13
8. Concluding work and coding	14
9. Wiring diagram	15
10. Customer information for the additional high-beam headlights	17

1. Parts list

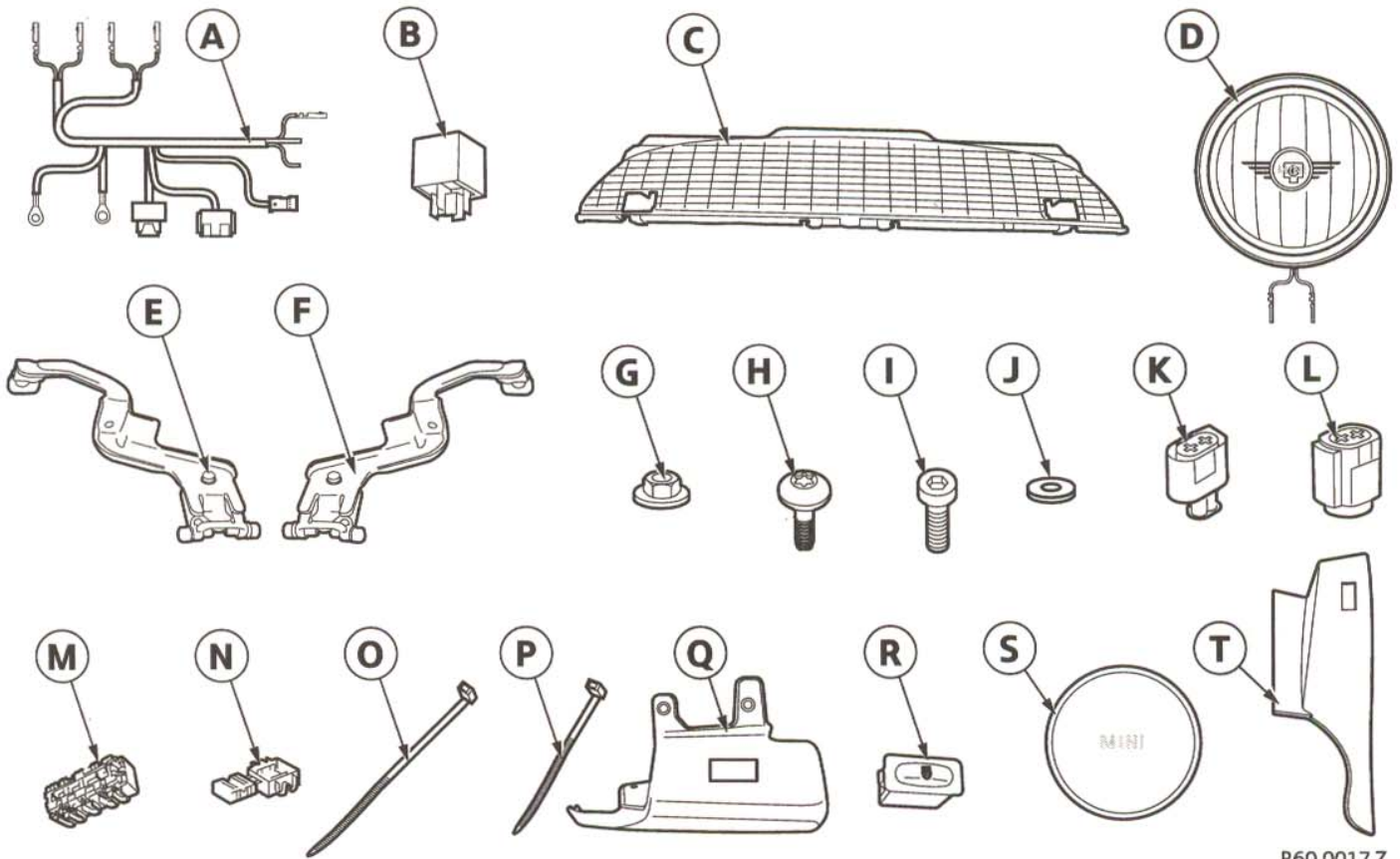

R60 0017 Z

Legend

- A Wiring harness
- B Control unit
- C Radiator grille (part of the holder and grille retrofit kit)
- D Additional high-beam headlights (2 x)
- E Left holder (part of the holder and grille retrofit kit)
- F Right holder (part of the holder and grille retrofit kit)
- G Self-locking hexagon nut M8 (2 x)
- H Screw M6 (2 x)
- I Screw M6 (4 x)
- J Shim M6 (8 x)
- K SW 2-pin socket casing (2 x)
- L SW 2-pin pin housing (2 x)
- M 5-way miniature connector
- N 2-way miniature connector (2 x)
- O Cable tie 445 x 4.8 mm (2 x)
- P Cable tie 200 x 3.6 mm (25 x)
- Q Knee protection on the driver's side (R55, R56, R57 cars only, not supplied with the retrofit kit)
- R Button (not supplied with the retrofit kit)
- S Headlight cover (2 x)
- T Trim (R60 cars only, included with the trim with button retrofit kit)

2. Preparatory work

	ISTA No.
Conduct a brief test	---
Disconnect the negative pole of the battery	61 20 900
The following components must be removed first of all	
Central radiator grille (no longer required)	51 13 000
Panel on central radiator grille (convert)	51 13 003
Bottom left dashboard trim	51 45 180
Knee protection on the driver's side (no longer required)	51 45 250
Front left door sill strip	51 47 000
Left cowl panel cover	51 13 123
Right cowl panel cover	51 13 124

3. Connection diagram

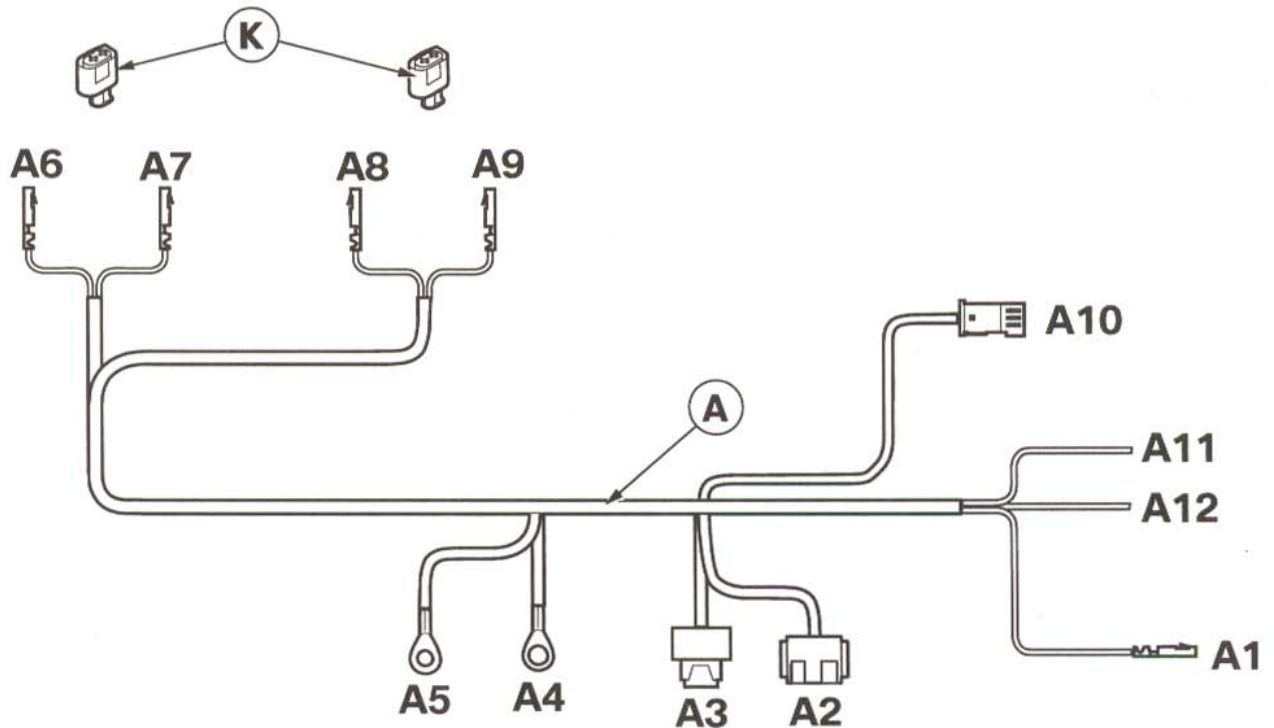

R56 0097 Z

Item	Designation	Signal	Cable colour/ Cross-section	Connection location in the car	Abbreviation/ Slot
A	Wiring harness	---	---	---	---
A1	Socket contact	Terminal 56a	GE/BL 0.75 mm ²	Cars without xenon light only With miniature connector M to the GE/BL cable from the footwell module Cars with xenon light only Connect to the footwell module or with miniature connector M to the GE/RT cable from the footwell module	X14260 PIN 4 X14260 PIN 41
A2	SW 9-pin relay base	---	---	To control unit B	---
A3	Fuse holder	---	---	---	---
A4	Eyelet M6	Terminal 31	BR	Terminal 31 support point under the engine compartment fuse holder	X165
A5	Eyelet M8	Terminal 30	RT/BL 2.5 mm ²	Terminal 30 support point in the engine compartment fuse holder	X2
A6	Socket contact	FSL	BL/RT 1.0 mm ²	With socket casing K to pin housing L on the left-hand additional high-beam headlight D	PIN 1
A7	Socket contact	Terminal 31L	BR 1.0 mm ²	With socket casing K to pin housing L on the left-hand additional high-beam headlight D	PIN 2
A8	Socket contact	FSR	BL/WS 1.0 mm ²	With socket casing K to pin housing L on the right-hand additional high-beam headlight D	PIN 1
A9	Socket contact	Terminal 31L	BR 1.0 mm ²	With socket casing K to pin housing L on the right-hand additional high-beam headlight D	PIN 2
A10	WS 4-pin socket casing	---	---	To button R	---
A11	Cable open	Terminal 58g	GR/RT 0.5 mm ²	With miniature connector N to the GR/RT cable of the footwell module	X14261 PIN 48
A12	Cable open	Terminal 15	GR 0.75 mm ²	With miniature connector N to the GR cable of the footwell module	X14261 PIN 12

4. Installation and cabling diagram

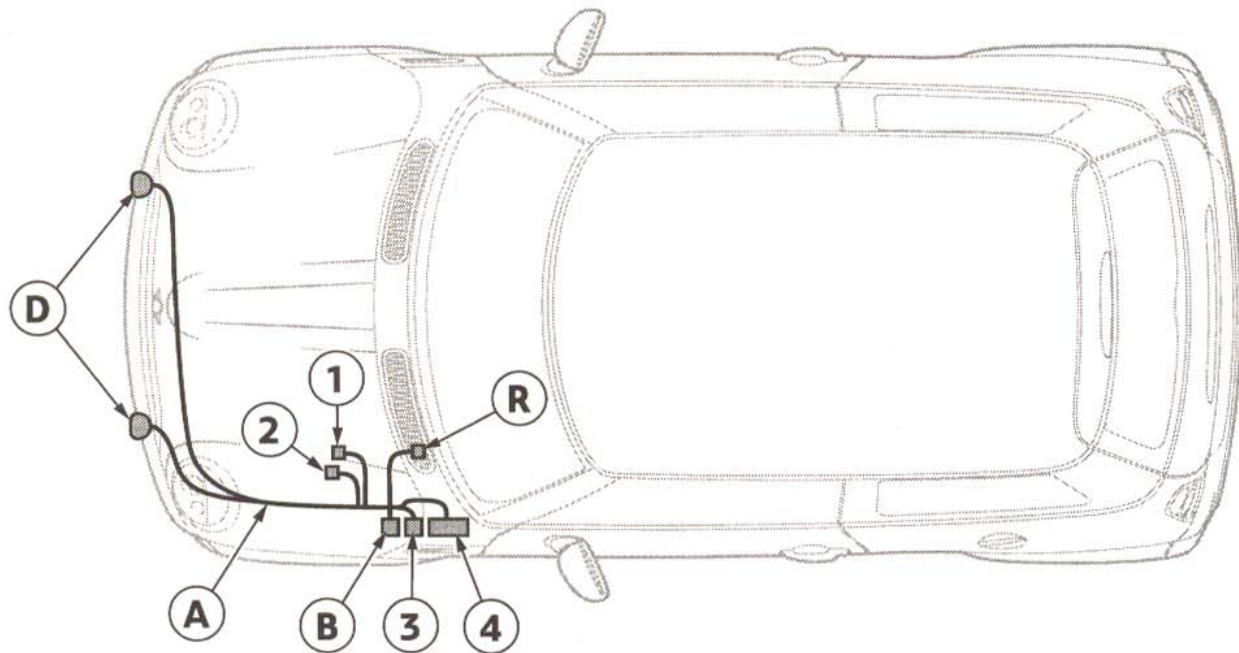

R56 0120 Z

Legend

- A** Wiring harness
 - B** Control unit
 - D** Additional high-beam headlights
 - R** Button
-
- 1** Terminal 30 pick-up on terminal 30 support point, **X2**
 - 2** Terminal 31 pick-up on terminal 31 support point, **X165**
 - 3** Fuse holder **A3**
 - 4** Footwell module, socket casing **X14260**

5. Installing and connecting the wiring harness

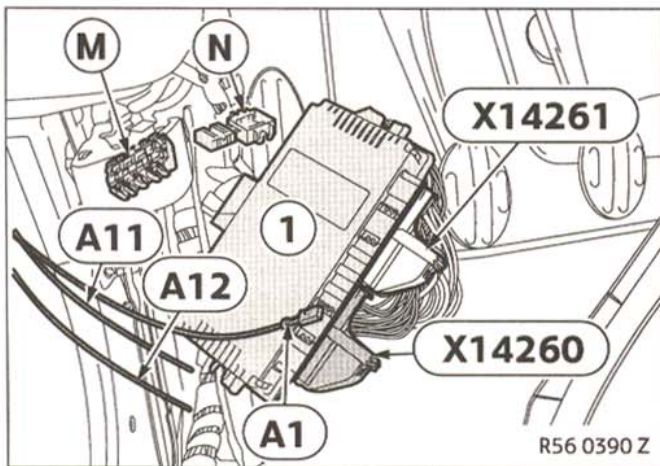

Release the footwell module (1) and socket casing **X14260** (SW/GR 51-pin) (see ISTA No. 61 35 015).

▶ The socket casing of **X14260** and **X14261** are both **SW**, the inner housing of the **X14260** is grey. ◀

Connect branch **A1** as follows to socket casing **X14260**:

Cars without xenon light only

Connect branch **A1**, GE/BL cable, using 5-way miniature connector **M** to the GE/BL cable of PIN 4.

Cars with xenon light only

▶ If PIN 41 is already occupied, connect branch **A1** using 5-way miniature connector **M**. ◀

Connect branch **A1**, GE/BL cable, to PIN 41.

All cars

Connect branches **A11** and **A12** as follows using 2-way miniature connectors **N** to socket casing **X14261**:

- Branch **A11**, GR/RT cable, to GR/RT cable from PIN 48
- Branch **A12**, GR cable, to GR cable from PIN 12

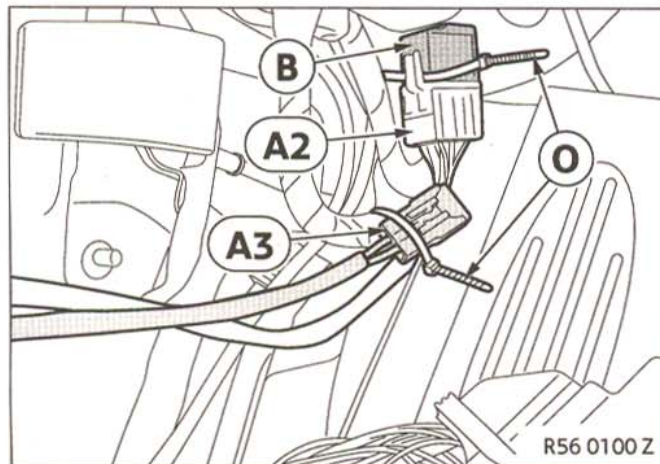

▶ Failure to observe the instructions regarding ESD (Electrostatic Discharge) protection as per ISTA RA 61 35 ... can damage the control unit **B**. ◀

Connect control unit **B** to branch **A2** (SW 9-pin relay base).

Secure branch **A2** and branch **A3** (fuse holder) to the standard wiring harness in the footwell on the driver's side using cable ties **O**.

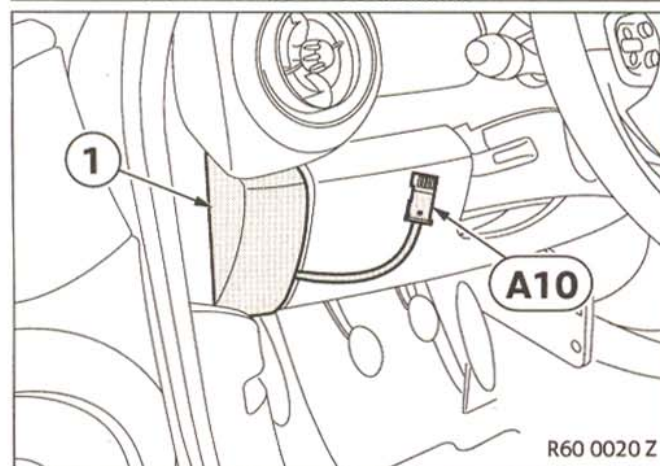

R60 cars only

Remove the standard trim on the driver's side (1) (no longer required).

Route branch **A10** (WS 4-pin socket casing) to the installation location for the driver's side trim (1).

5. Installing and connecting the wiring harness

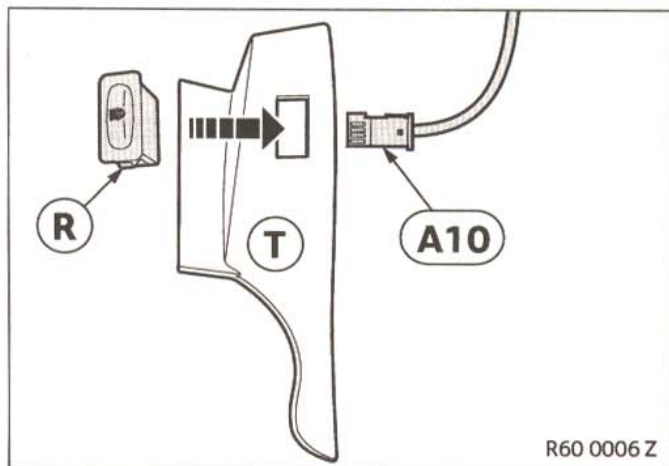

Insert button **R** as shown into the driver's side trim **T**.

Connect branch **A10** (WS 4-pin socket casing) to button **R** and fit the driver's side trim **T**.

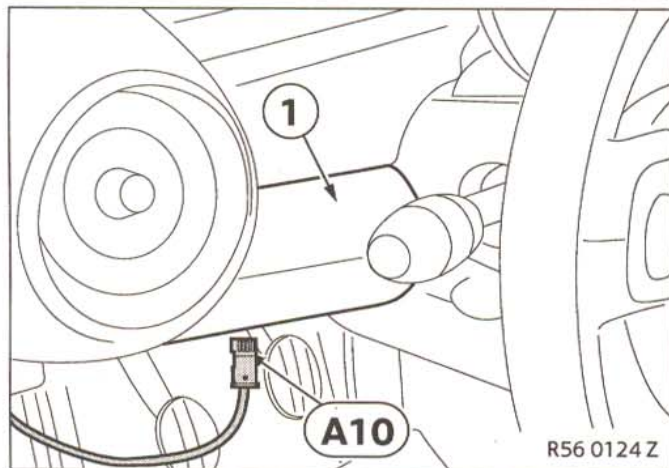

R55, R56 and R57 cars only

Remove the standard knee protection on the driver's side (1) (no longer required).

Route branch **A10** (WS 4-pin socket casing) to the installation location for the knee protection on the driver's side (1).

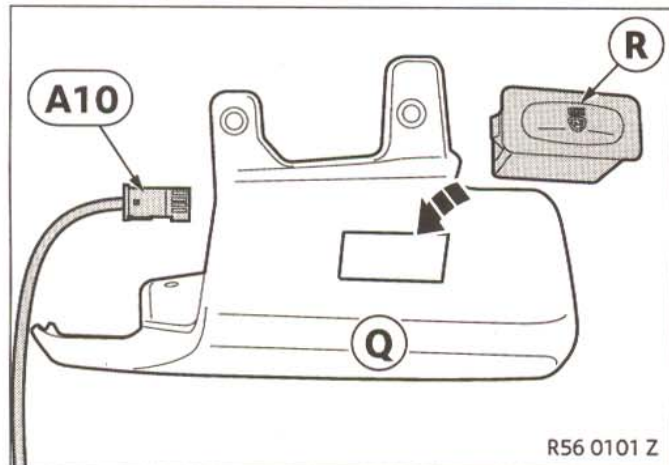

Insert button **R** as shown into the knee protection on the driver's side **Q**.

Connect branch **A10** (WS 4-pin socket casing) to button **R** and fit the knee protection on the driver's side **Q**.

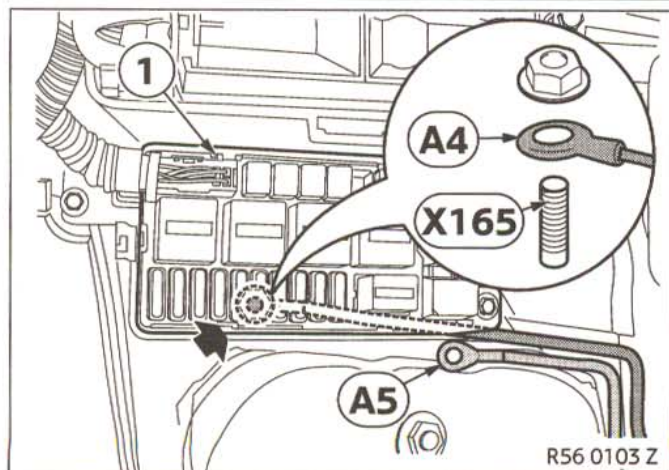

All cars

Route branches **A4–A5** to the engine compartment fuse holder (1).

Loosen the engine compartment fuse holder (1) and fold it out of the way.

Connect branch **A4** (eyelet M6) to terminal 31 support point **X165**.

Connect the engine compartment fuse holder (1).

5. Installing and connecting the wiring harness

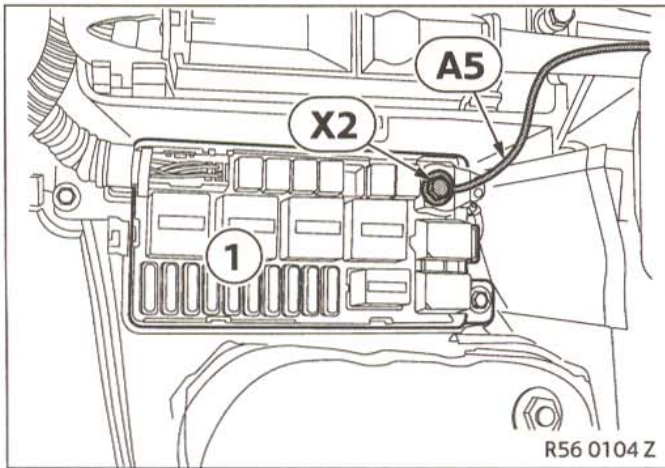

Connect branch **A5** (eyelet M8) to terminal 30 support point **X2** of engine compartment fuse holder (1).

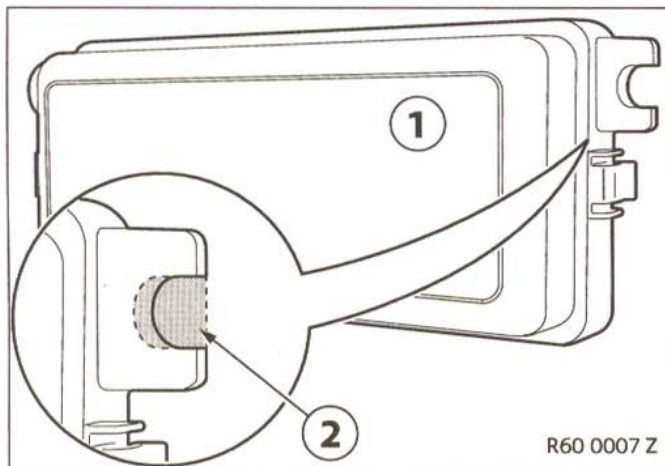

Mill out the engine compartment fuse holder (1) in the area marked (2) accordingly.

Install the cover for the engine compartment fuse holder (1).

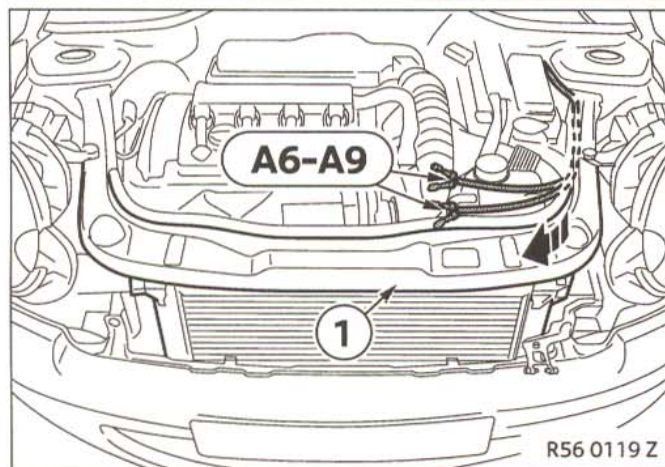

Route branches **A6-A9** along the standard wiring harness to the front end (1).

Seal the cable ducts.

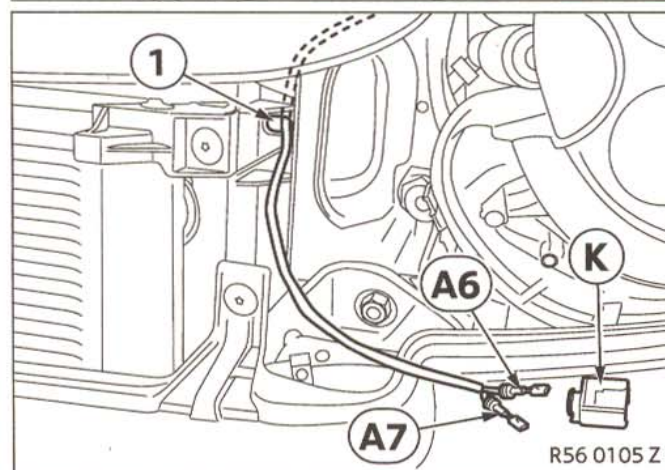

Route branches **A6-A7** through the opening (1) in the front end.

Connect branches **A6** and **A7** to socket casing **K** (SW 2-pin) as follows:

- Branch **A6**, BL/RT cable, to PIN 1
- Branch **A7**, BR cable, to PIN 2

6. Installing the additional high-beam headlights holder

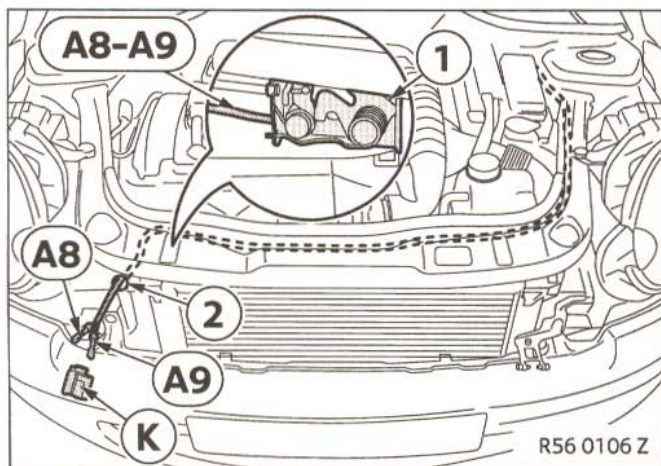

Route branches **A8-A9** along the bonnet release guide through the opening (2) in the front end.

☐ Ensure that the engine compartment lid catch is freely mobile (1). Branches **A8-A9** must not be damaged by the engine compartment lid catch (1). ◀

Connect branches **A8** and **A9** to socket casing **K** (SW 2-pin) as follows:

- Branch **A8**, BL/WS cable, to PIN 1
- Branch **A9**, BR cable, to PIN 2

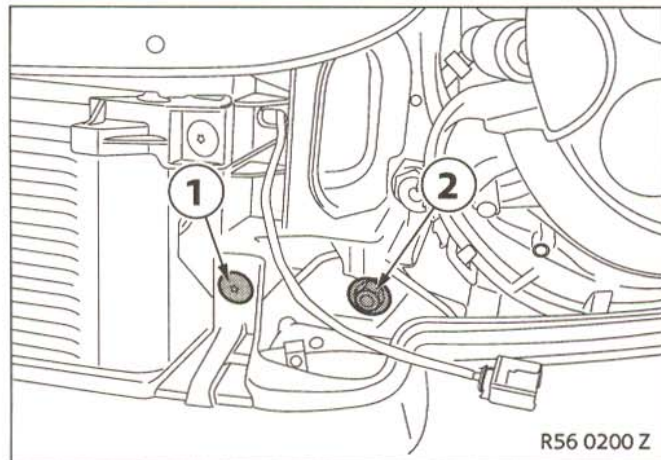

R55, R56, R57 cars only

Remove the standard screw connections from the bumper trim (1) and support (2), they are no longer required.

Proceed in exactly the same way on the right-hand side.

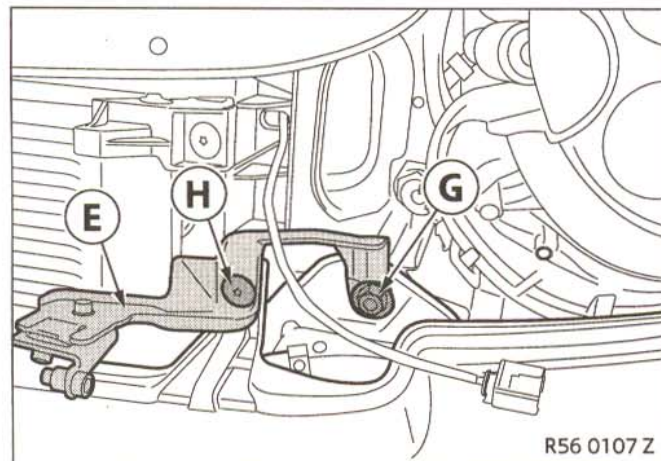

☐ The tightening torque of hexagon nut **G** is 22 Nm. ◀
Screw the left holder **E** using hexagon nut **G** and screw **H**.

Proceed in exactly the same way for the right-hand holder **F**.

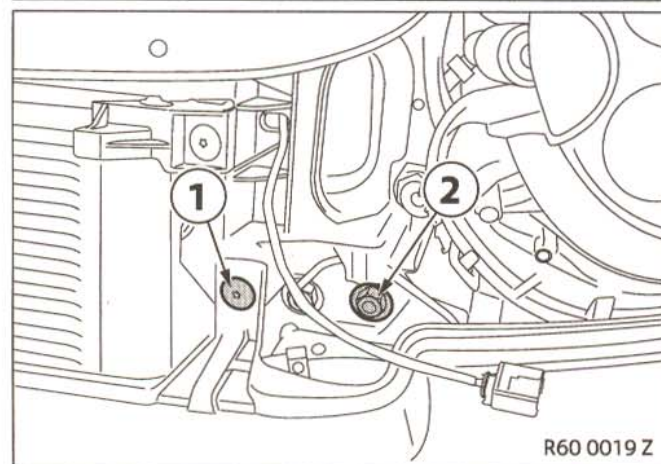



R60 cars only

Remove the standard screw connections from the bumper trim (1) and support (2), they are no longer required.

Proceed in exactly the same way on the right-hand side.

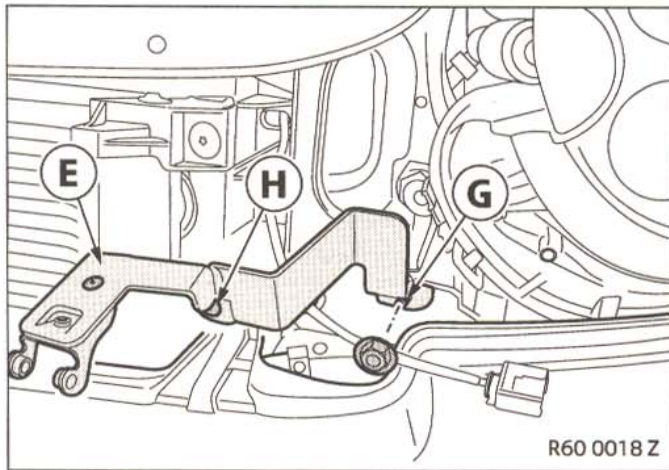
6. Installing the additional high-beam headlights holder



 The tightening torque of hexagon nut **G** is 22 Nm. ◀
Screw the left holder **E** using hexagon nut **G** and screw **H**.

Proceed in exactly the same way for the right-hand holder **F**.

7. Converting the radiator grille and installing the additional high-beam headlights

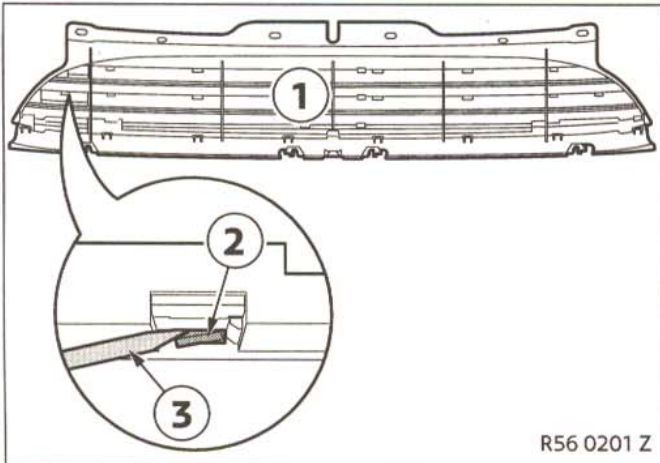

R55, R56, R57 cars only with radiator grille in chrome

▶ In order to avoid damage to the chrome bars, place the central radiator grille (1) on a protective cloth. ◀

Remove the adhesive strips on the retaining lugs (2) using a screwdriver (3).

▶ Carefully push the retaining lugs (2) downwards and remove the chrome strips from the radiator grille (1). ◀

Fit the chrome strips onto the central radiator grille C. To secure them in place, apply hot glue to the retaining lugs (2).

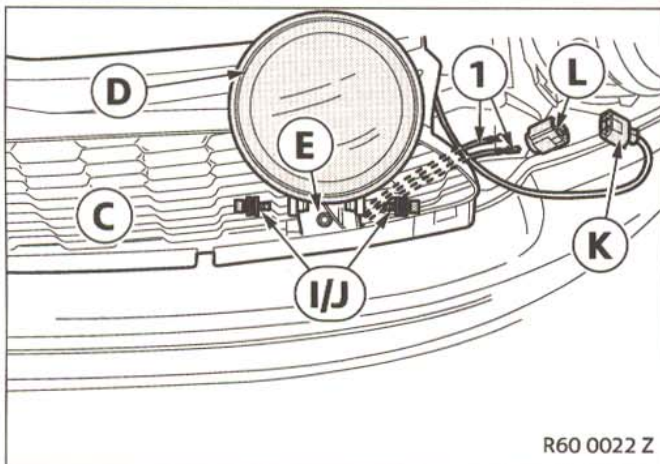

All cars

Apply the decorative strip to the central radiator grille C and loosely push it into place.

First loosely screw on the additional left-hand high-beam headlight D into the final fitting position using screws I and 2 shims J.

Route connecting cable (1) below holder E through the central radiator grille C to socket casing K.

Connect connecting cable (1) of the left-hand additional high-beam headlight D as follows to pin housing L (SW 2-pin):

- Cable, VI/SW cable, to PIN 1
- Cable, BR cable, to PIN 2

Connect pin housing L to socket casing K.

Proceed in exactly the same way for the right-hand headlight D.

Secure central radiator grille C in place.

8. Concluding work and coding

This retrofit system does not require coding.

- Connect the battery
- Conduct a brief test
- Conduct a function test
- Re-fit the car components as required
- Print out section 10 of these installation instructions and give it to the customer

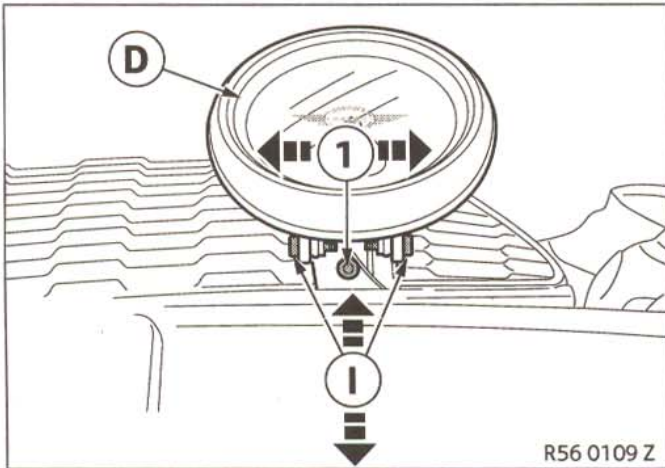

Adjust the additional high-beam headlights **D** as follows with the headlight adjustment tool:

Vertical setting

Loosen the screw (1) and adjust the vertical setting

Horizontal setting

Loosen both screws **I** and adjust the horizontal setting



The tightening torque of screw (1) and **I** is 12 Nm. ◀

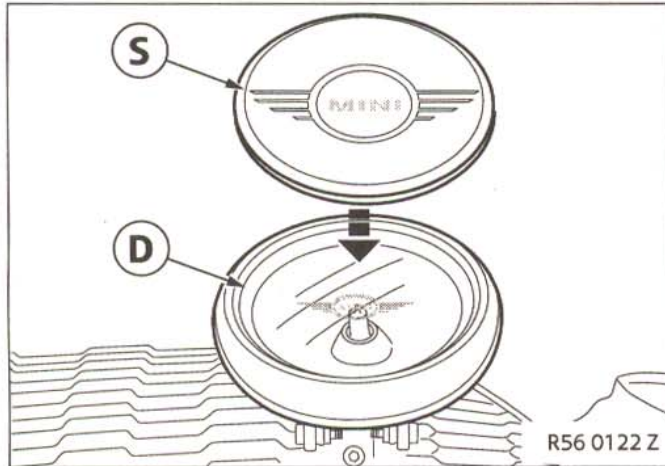

Place headlight covers **S** on the additional high-beam headlights **D**.



Risk of damage from overheating. Never use the additional high-beam headlights **D** when the headlight covers **S** are fitted. ◀

9. Wiring diagram

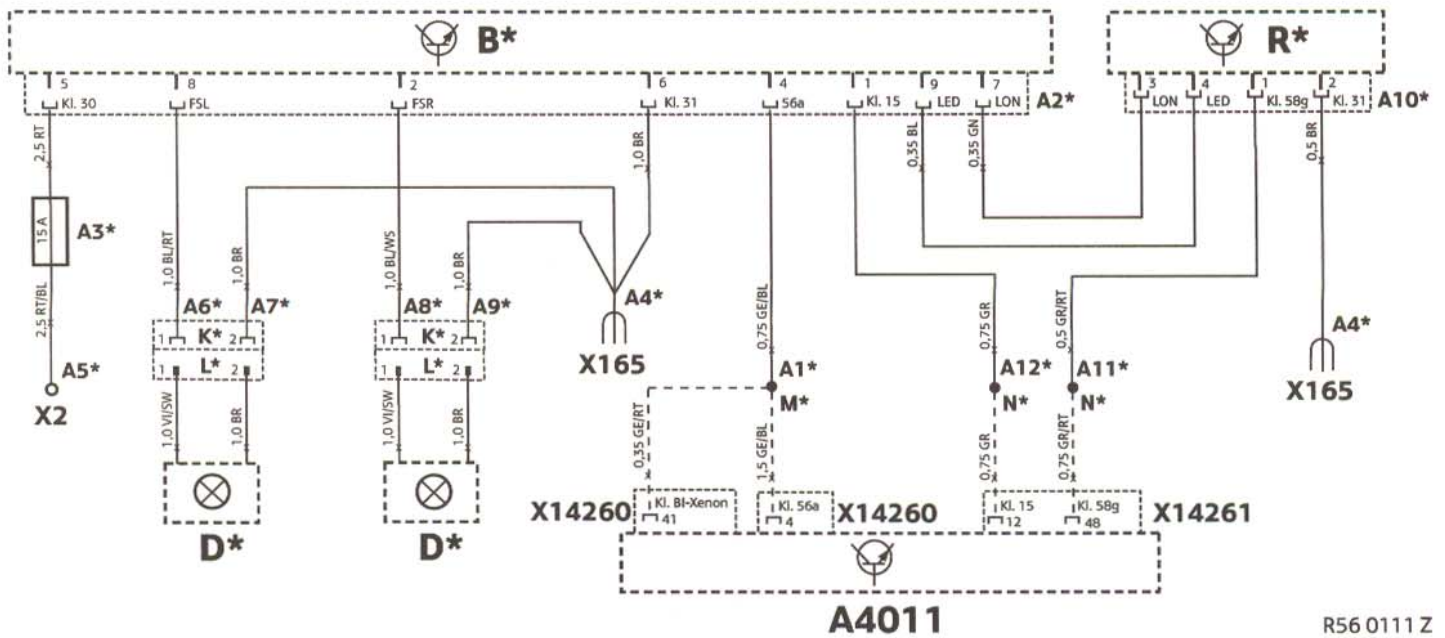

R56 0111 Z

Legend

- A4011** Footwell module
- A1*** Socket contact
- A2*** SW 9-pin relay base
- A3*** Fuse holder
- A4*** Eyelet M6
- A5*** Eyelet M8
- A6*** Socket contact
- A7*** Socket contact
- A8*** Socket contact
- A9*** Socket contact
- A10*** WS 4-pin socket casing
- A11*** Cable open
- A12*** Cable open

- B*** Control unit

- D*** Additional high-beam headlights

- K*** SW 2-pin socket casing

- L*** SW 2-pin pin housing

- M*** 5-way miniature connector

- N*** 2-way miniature connector

9. Wiring diagram

Legend

R*	Button
X2	Terminal 30 support point in the engine compartment fuse holder
X165	Terminal 31 support point under the engine compartment fuse holder
X14260	SW/GR 51-pin socket casing
X14261	SW 51-pin socket casing

All the designations marked with an asterisk (*) apply only to these installation instructions or this wiring diagram.

Cable colours

BL	Blue
BR	Brown
GE	Yellow
GN	Green
GR	Grey
SW	Black
RT	Red
VI	Violet
WS	White

10. Customer information for the additional high-beam headlights

This customer information must be printed out and given to the customer.

Pictograms



Denotes instructions that draw your attention to dangers.



Denotes instructions that draw your attention to special features.

◀ Denotes the end of the instruction or other text.



Consult the applicable state and regional laws governing the use of additional headlights. Some countries, for instance, forbid the simultaneous use of four lights, while others ban their use on public roads altogether and require that the additional high-beam headlights are equipped with optional headlight covers when not in use. ▶



Risk of damage from overheating. Never use the additional high-beam headlights when the optional headlight covers are fitted.

Operating the additional high-beam headlights

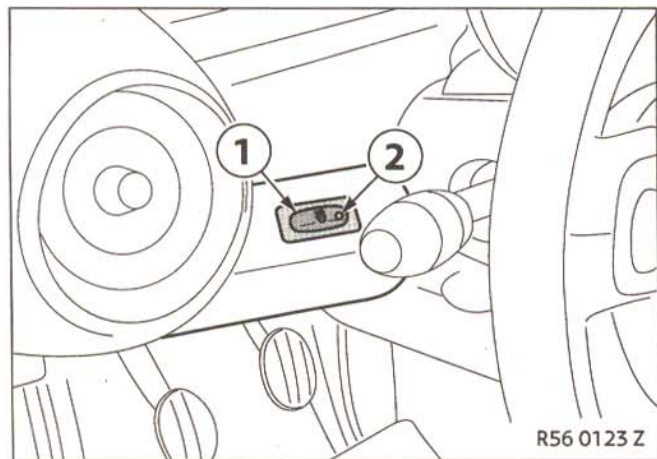

Switching the additional high-beam headlights on automatically

▶ Once activated, the additional high-beam headlights light up automatically when the headlights or headlight flash are switched on.

Whenever you turn the ignition off/on, you must re-activate the additional high-beam headlights. The figure above shows R55, R56, R57 cars. The figure below shows R60 cars. ▶

- Switch on the ignition or start the engine
- Press the button (1) to activate

The additional high-beam headlights are activated when the green control light (2) lights up in the button (1).

- Switch the headlights on or actuate the headlight flash

The additional high-beam headlights light up along with the headlights or headlight flash.

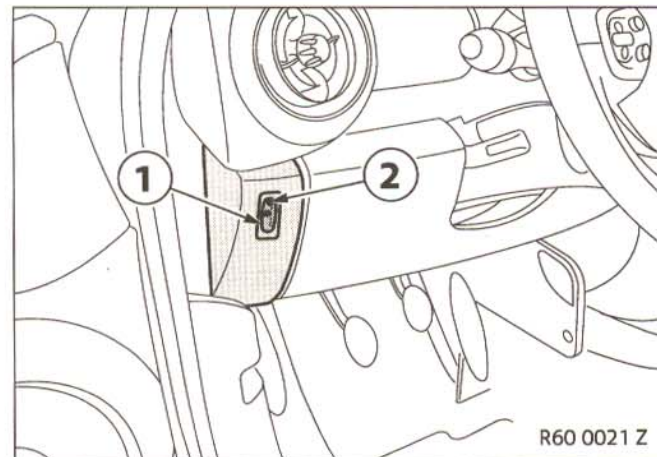

Switching the additional high-beam headlights on manually

- Switch on the ignition or start the engine
- Switch the headlights on or actuate the headlight flash
- Press the button (1) to switch on the additional high-beam headlights

The additional high-beam headlights light up along with the headlights or headlight flash.

Switching off the additional high-beam headlights

Switch off the headlights or press the button (1) again.

10. Customer information for the additional high-beam headlights

Changing the bulb

Lamps and lights are an important part of the car's safety features. Appropriate care should therefore be used when handling them. If you are not familiar with such work, have it performed by your MINI service centre.

 Bulb required: **H3** (55 W). Do not touch the glass rounded section of the bulb with your bare hands, since even slight contamination can burn onto the surface and reduce the bulb's service life. Use a clean cloth, a paper towel or similar to take hold of the bulb at its base. ◀

 When carrying out any work on the car's electrical system, switch off the device you are working on or disconnect the battery's negative terminal, otherwise you may cause a short-circuit. Always read any instructions provided by the bulb's manufacturer in order to avoid injury and/or damage when changing the bulb. ◀

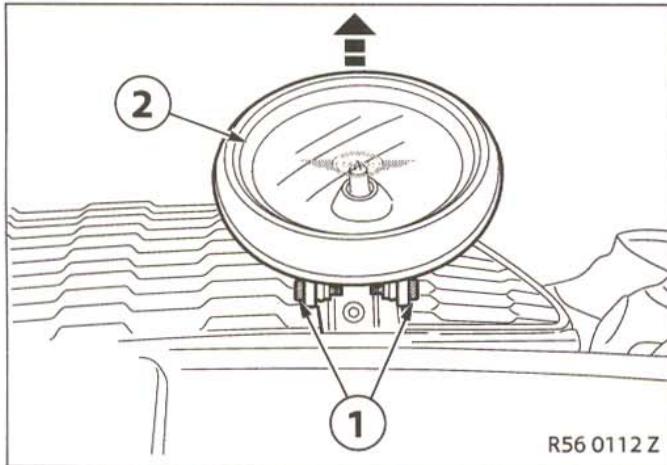

Unscrew both screws (1) and pull the additional high-beam headlight (2) carefully forwards.

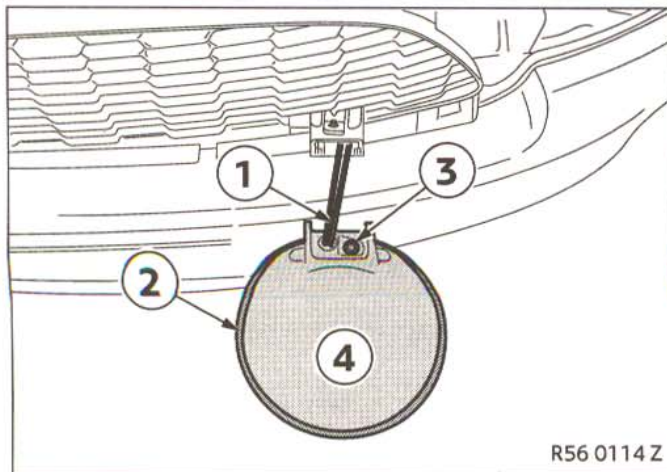

 In order to avoid damaging the cable (1), hold the additional high-beam headlight (2) with one hand. ◀
Unscrew the Allen screw (3) and remove the housing (4).

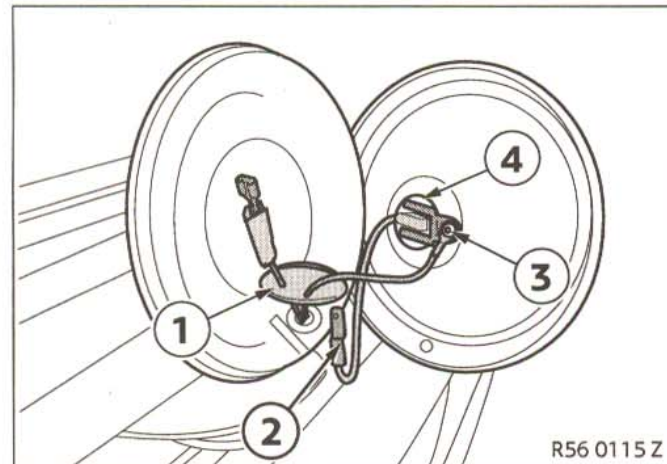

Remove the rubber cap (1) and disconnect the plug (2).
Loosen the screw (3), remove it and change the bulb (4).
The headlight is reassembled in the reverse order.

 The tightening torque of the screws is 12 Nm.
The position of the additional high-beam headlight must be adjusted after the bulb has been changed. ◀

10. Customer information for the additional high-beam headlights

Adjusting the additional high-beam headlights

☐ If you are not having your additional high-beam headlights adjusted by your MINI service centre, you can adjust them yourself even without a headlight adjustment tool. The steps for how to do this are described using the example of the left-hand additional high-beam headlight. The right-hand additional high-beam headlight is adjusted in exactly the same way.

To adjust the headlights, park your unladen car on even ground and around 5 - 10 m perpendicularly to a vertical wall. ◀

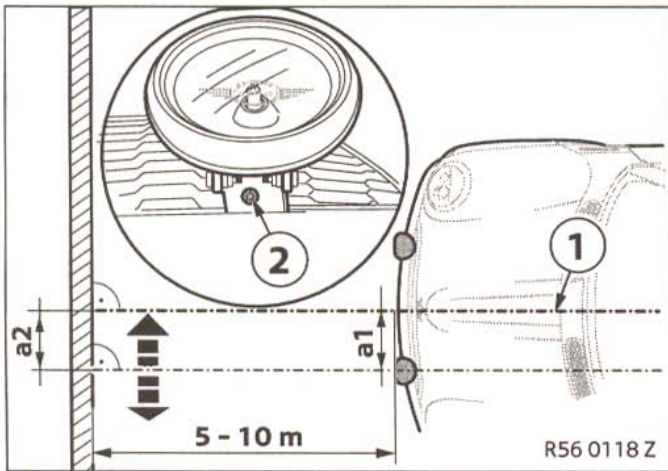

Testing the vertical setting

- Measure the distance **a1** from the centre of the cone of light on the wall to the extension of the vehicle's longitudinal axis (1).
- Measure the distance **a2** from the centre of the cone of light on the wall to the extension of the vehicle's longitudinal axis (1).

If distances **a1** and **a2** are not identical, adjust the vertical position as follows:

Adjusting the vertical position

- Loosen the screw (2) and rotate the additional high-beam headlight so that distances **a1** and **a2** are the same.

☐ The tightening torque of the screw (2) is 12 Nm. ◀

- Tighten the screw (2) to 12 Nm.

Testing the horizontal position

- Measure the height **h1** from the centre of the additional high-beam headlight to the floor.
- Measure the height **h2** from the centre of the cone of light on the wall to the floor.

If heights **h1** and **h2** are not identical, adjust the horizontal position as follows:

Adjusting the horizontal position

- Loosen both screws (1) and rotate the additional high-beam headlights so that heights **h1** and **h2** are the same.

☐ The tightening torque of the screw (2) is 12 Nm. ◀

- Tighten the screws (1) to 12 Nm.

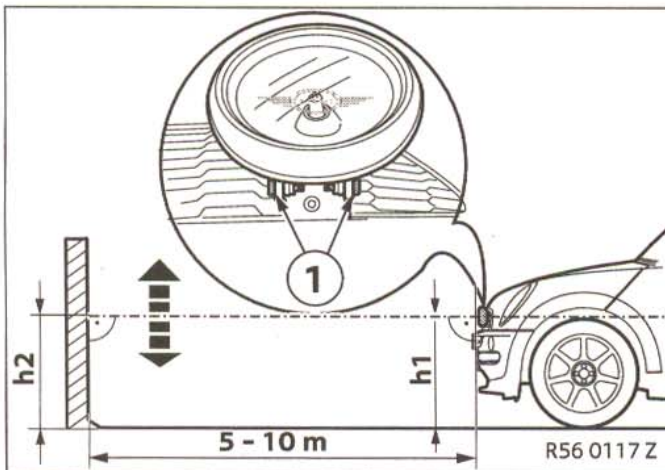

10. Customer information for the additional high-beam headlights

Changing the fuse

! When carrying out any work on the car's electrical system, switch off the device you are working on or disconnect the battery's negative terminal, otherwise you may cause a short-circuit.

Do not repair a burnt-out fuse or replace it with a fuse of another colour or Ampere rating, since overloaded electrical cables could cause a fire in the car. ◀

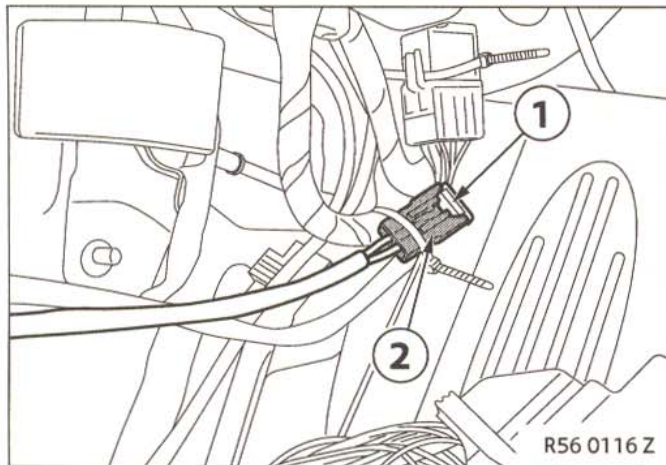

Fuse required (1): **15 A**

The fuse (1) for the additional high-beam headlights is located in the footwell on the driver's side, behind the side trim.

Remove and change the fuse (1) from the fuse holder (2).

If the fuse (1) blows repeatedly, have your MINI service centre investigate the cause.

Cleaning and care

Use a soft damp cloth to clean the additional high-beam headlights. Do not use abrasive or corrosive cleaning agents.