

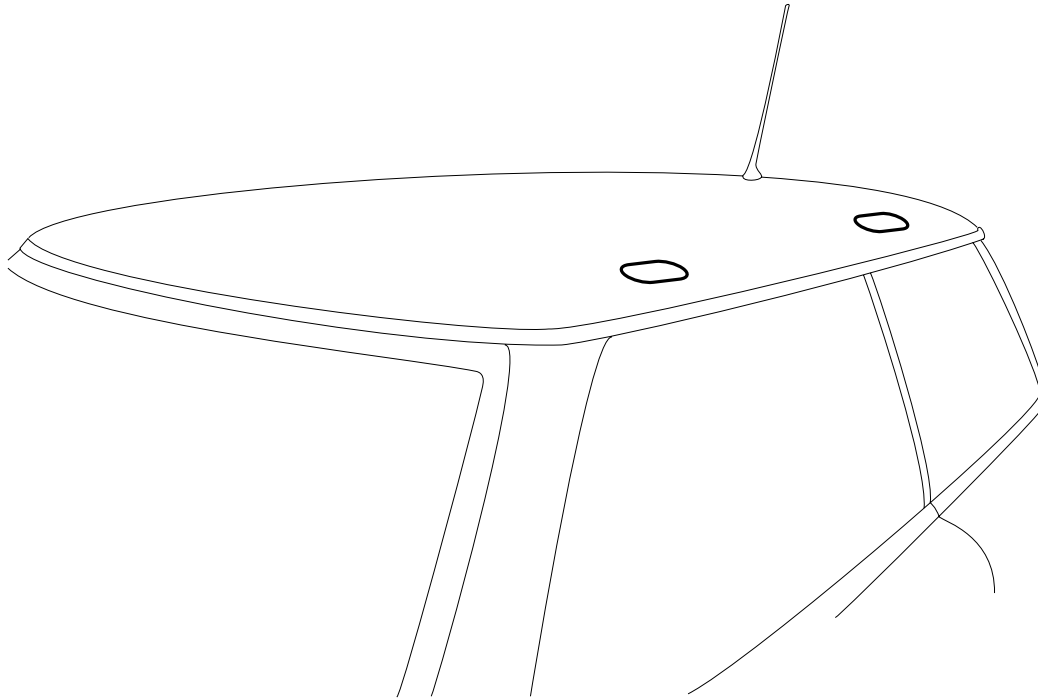

Parts and Accessories Installation Instructions



050 0096 V

Installation kit for roof rack MINI One, Cooper (R 50); MINI Cooper S (R 53)

The installation time is approx. 1.5 hours, which may vary depending on the condition of the car and the equipment in it.

Retrofit / Installation kit No. 82 79 136,426

Contents

Section	Page
Important information	3
1. Parts list	4
2. To affix the templates on to the exterior roof skin	5
3. To drill the holes	7
4. To install the stud bolts	9
5. To install the cover caps	10

Important information

The retrofit kit is for use within the MINI dealership organisation only.

Target group

The target group for these installation instructions is specialist staff trained on MINI cars. All servicing, repair, installation and adjustment work on cars is completed at your own risk.

All work is to be carried out using current MINI

- Repair manuals (see Technical Information System),
- Servicing handbooks,
- Work instructions,

in a rational sequence with the prescribed tools (special tools) and taking into account the relevant health and safety regulations.

Safety instructions



Keep to the specific tightening torque values for screw connections. ◀

Drilling instructions

Coat twist drills with grease before drilling the holes to prevent drill chips falling into the body cavities. Remove drill chips carefully, deburr holes and treat them with the usual MINI anti-corrosion coatings.

Installation information

The work on the car is only shown on one side. The work on the other side of the car is to be carried out in exactly the same way.

Abbreviations

HL / VL = Rear left / Front left

HR / VR = Rear right / Front right

Tools required

Scissors
Adhesive tape
Tap measure
Hammer
Centre punch
Drill and 3 mm and 6 mm twist drill bits
Step drill or peel drill up to 10 mm
Deburring tool
Zinc powder paint
Flat screwdriver
8 mm Allen key
Torque wrench
Feeler gauge
Plug gauge (Part No. 82 79 0 140 429)
Cylindrical keyhole saw (Part No. 83 31 0 141 898)

1. Parts list

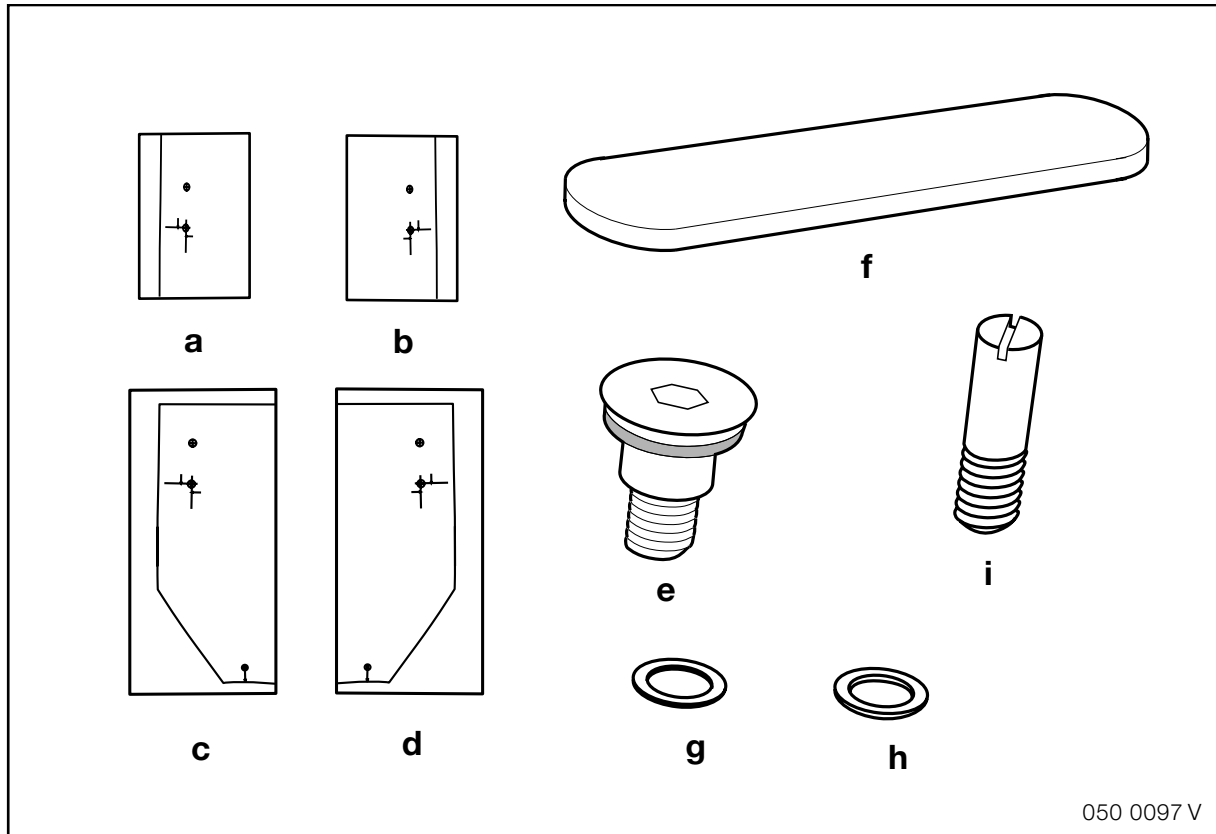

a	Template VL	1
b	Template VR	1
c	Template HL	1
d	Template HR	1
e	Stud bolt with seal	8
f	Cover caps (can be finished in body colour)	4
g	Spacer washers 0.5 mm	16
h	Spacer washers 1 mm	16
i	Centring bolt	1

2. To affix the templates on to the exterior roof skin



Only use the templates from the original installation kit, in other words do not use copies. ◀

Cut out the VL, VR, HL and HR templates **precisely** along the marked lines.

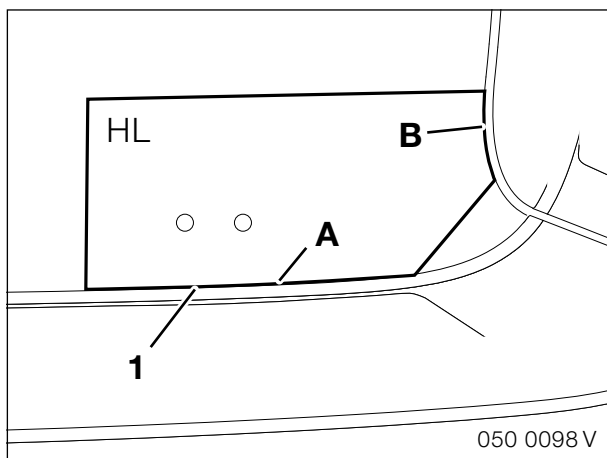

Place the cut edge (A) of template HL on the roof strip (1) at the rear left of the roof.
Place cut edge (B) flush with the rear roof edge.
Secure the template with adhesive tape.

Affix template HR in the same way on the right-hand side of the roof.

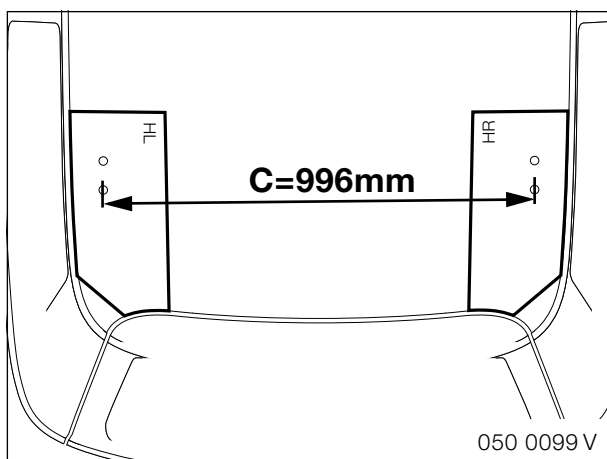

Check that the distance between the HL and HR templates is $C = 996$ mm.
If this is not the distance between the two templates, correct the two templates uniformly sideways relative to the roof strips.



The templates must be affixed precisely symmetrically on the roof. ◀

When the templates are positioned precisely, secure them with adhesive tape.

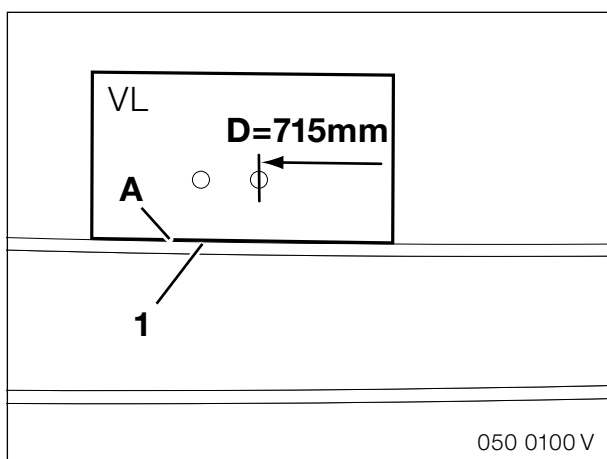

Place template VL at the marked distance $D = 715$ mm from template HL with the cut edge (A) on the roof strip (1) at the front left of the car.

Secure the template with adhesive tape.

Affix template VR in the same way on the right-hand side of the roof.

2. To affix the templates on to the exterior roof skin

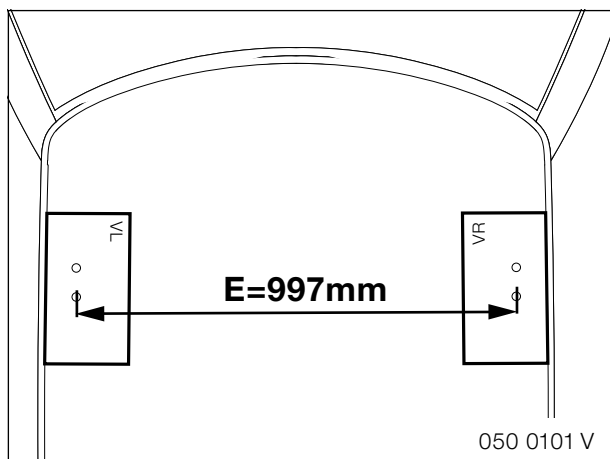

Check that the distance between the VL and VR templates is $E = 997$ mm. If this is not the distance between the two templates, correct the two templates uniformly sideways relative to the roof strips.

 The templates must be affixed precisely symmetrically on the roof. ◀

Check all the dimensions again. When the templates are positioned precisely, secure them with adhesive tape.

3. To drill the holes



There is a total of eight threads M10 to take the stud bolts (e) in the side frame of the car under the exterior roof skin.

The distance between the threads and the exterior roof skin is approx. 10 mm.

You must drill eight holes with a diameter of 15 mm in the exterior roof skin. The holes must be precisely central to the threads in the side frame. ◀



To ensure that you do not damage the threads in the side frame the penetration depth of all the tools you use must not exceed 10 mm.

The 15 mm diameter of the holes must not be exceeded by more than 1 mm since otherwise the car roof may leak.

When you centrepunch, drill and deburr the holes, only press gently on the roof to prevent deformations in the exterior roof skin. ◀

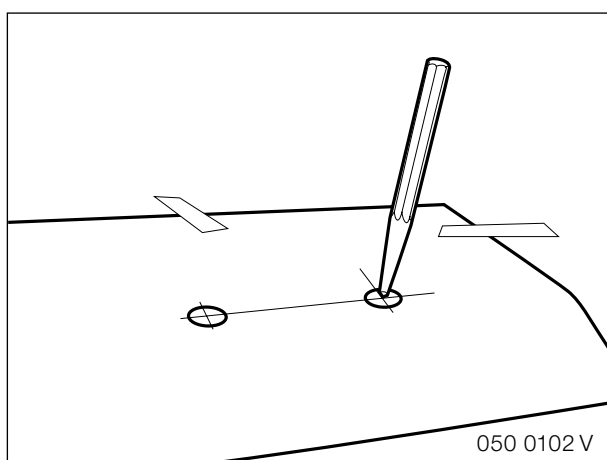

Gently centrepunch all eight holes through the templates. Remove the templates. Mask the working area to protect it.



when drilling neighbouring holes always drill one hole first until the position of the thread is visible.

If the position of the thread has not been reached precisely with the template the position of the centrepunch mark for the second hole may be corrected if necessary. The distance between the pairs of holes is precisely 90 mm. ◀

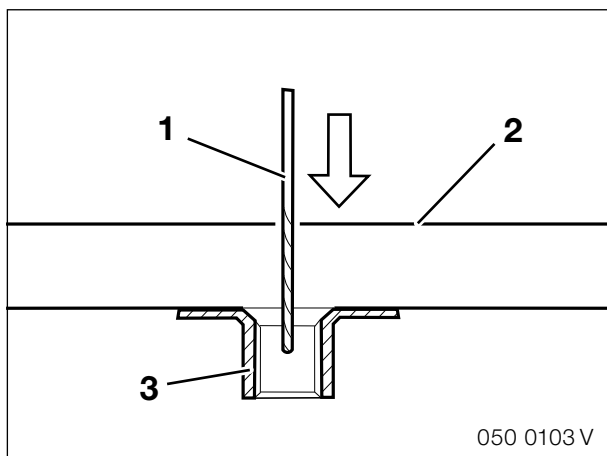

Pre-drill the holes with a diameter of 3 mm.

Then check by hand with the drill bit whether the thread is below the hole. Insert the drill bit (1) into the exterior roof skin (2) vertically through the hole. It must be possible to insert the drill bit at least 20 mm into the hole. Otherwise locate the thread (3) in the side frame with the drill bit and then make a fresh centrepunch mark and drill a new hole.

Enlarge the hole to 6 mm.

The thread can be seen through the hole. Check whether the thread is located precisely centrally below the hole.

If the thread is not precisely central under the hole the hole must be carefully reworked with a round file until it is precisely central over the hole.

If necessary correct the centrepunch marking for the neighbouring hole in the same direction.

3. To drill the holes

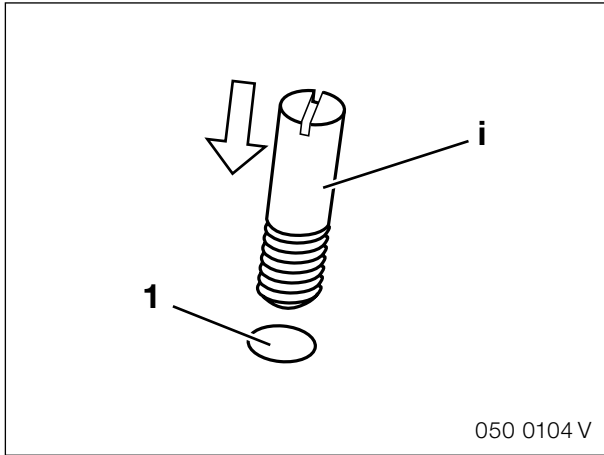

Enlarge the hole (1) to 10 mm using a step drill or peeling drill bit.

 If the centring bolt (i) cannot be inserted easily and fully into the thread in the side frame the hole must be reworked. ◀

Screw the centring bolt (i) into the thread in the side frame. Tighten it gently.

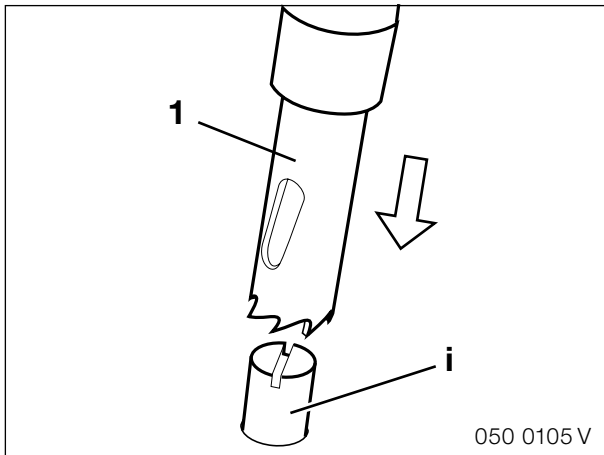

 The centring bolt (i) guides the cylindrical keyhole saw to ensure that the hole is precisely central and not too large. ◀

 Only press the cylindrical keyhole saw gently to prevent deformations in the exterior roof skin. ◀

Place the cylindrical keyhole saw (1) on the centring bolt (i) and drill the hole.

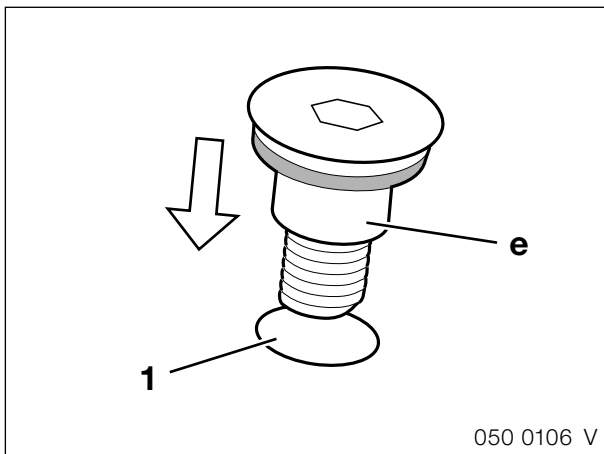

Deburr the edges of the hole.

 The stud bolts (e) have a micro-encapsulated screw locking device. This screw locking device must not be damaged until the stud bolts are installed in their final positions. ◀

Screw in one stud bolt (e) through two turns and check that it moves easily.

It may be necessary to enlarge the hole (1) carefully with the deburring tool.

Carefully remove or extract all the chips.

Protect the holes from corrosion with zinc dust paint. Follow the instructions for use supplied with the zinc dust paint.

4. To install the stud bolts

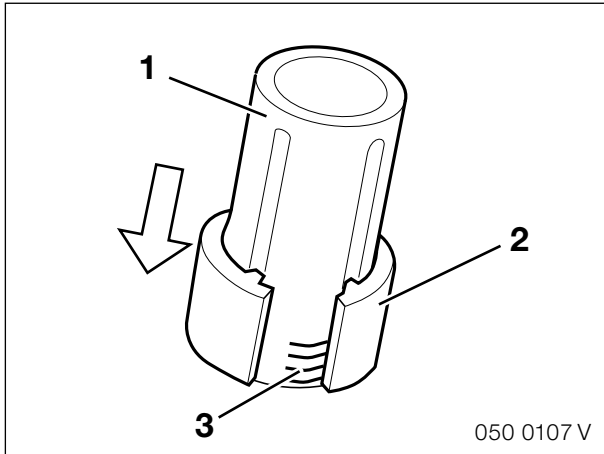

To ensure that the stud bolts are sealed well, the different distances to the exterior roof skin must be compensated with spacer washers. ◀

The plug gauge (1) (Part No. 82 79 0 140 429) is designed to check this distance. The scale on the plug gauge is adjusted such that the lowest scale mark defines the zero position of the thread distance. If the slide is flush with the lowest scale mark, no spacer washer is required. If the slide points to scale marks above this zero position, 0.5 mm or 1 mm spacer washers must be placed on the stud bolt for each scale mark. Insert the plug gauge (1) with the closed side pointing downwards into the finished hole until it contacts the side frame.

The slide (2) must be in full contact with the exterior roof skin.

The required distance can be read off the scale (3) in mm.

Produce the required distance by combining the spacer washers (g, h).

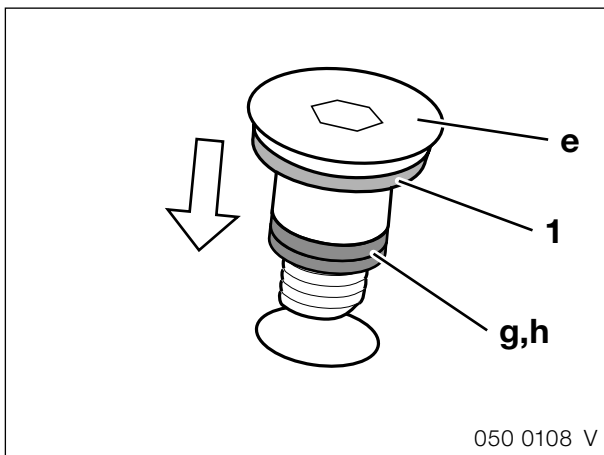

Place the spacer washers on the stud bolts (e) and secure them with adhesive or grease to prevent the washers falling off the bolts as you install them. Screw in the stud bolts (e) with the appropriate spacer washers (g, h).



Ensure that the seal (1) on the stud bolts creates a uniform seal on the exterior roof skin.

The height of the seal must not exceed 2 mm when it is installed. ◀

Tighten with a torque of 10 Nm.

Check that the seal does not exceed the maximum height of 2 mm using a feeler gauge. If necessary correct the number of spacer washers.

5. To install the cover caps

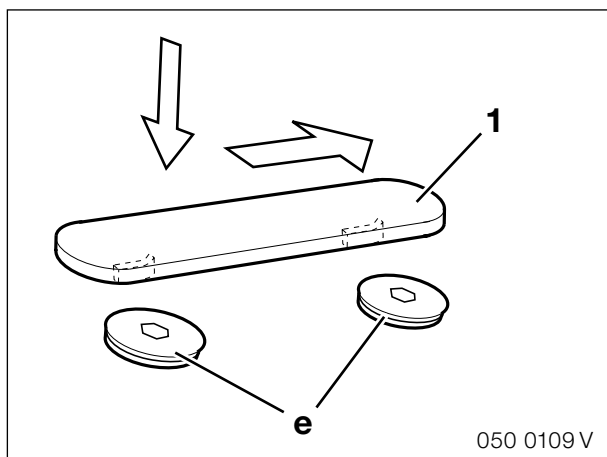

Place the cover caps (1) on both stud bolts (e) and push them backwards until they engage.