

Parts and Accessories.

Installation instructions.



John Cooper Works Upgrade Kit

MINI Cooper S (R 53)

MINI Cooper S Convertible (R 52)

The installation instructions apply only to vehicles with John Cooper Works tuning kit (11 12 0 302 673, 11 12 0 303 287)

Retrofit kit No.: 11 12 0 395 131

Installation time

The installation time of approx. 1.0 hours can vary depending on the condition and equipment of the vehicle.





Important information

These installation instructions are mainly intended for use in the MINI dealership network and by authorised BMW Service Centres;

The target group of these installation instructions are technical personnel trained on MINI vehicles with corresponding technical know-how.

All work is to be carried out with the aid of currently valid MINI repair instructions, schematic circuit diagrams, maintenance manuals and working instructions in rational order with the specified tools (special tools) while paying particular attention to valid safety regulations.

Important information that must be observed after installing the John Cooper Works Upgrade Kit and to which the customer's attention should be drawn:

-  It is recommended to use only 98 RON (octane) fuel or fuel with the highest available octane number. (95 RON fuel 91 AKI minimum) ◀
-  The service and maintenance intervals are the same as for the standard production vehicles. ◀
-  NGK BKR 7 EQUIP spark plugs are used and should be fitted at each subsequent service and maintenance interval. ◀
-  The **air cleaner element** with part number **13 72 0 395 826** is installed. It must be used at all subsequent service and maintenance intervals. ◀

In order to avoid unnecessary additional expenditure/costs, if any problems regarding installation, assembly or operation are encountered, after spending a little time on attempting to finding the problem (approx. 0.5 hour), an enquiry, including the vehicle identification number, part number of the installed retrofit kit and a detailed description of the problem, should be sent without delay to Technical Support via the Aftersales Assistance Portal (ASAP) .

Do not archive the printout of these Installation Instructions as daily updates are conducted through ASAP!

Refer to ASAP for explanations of the pictographs.

All illustrations show LHD vehicles. Carry out the same procedure analogously on RHD vehicles.

Pictographs:



identifies information that draws attention to specific requirements.

◀ identifies the end of an information or warning text.

When installing cables/wires, particular attention must be paid to ensure that they are not bent, kinked or damaged. The costs incurred will not be reimbursed by BMW AG.

Additionally installed cables/wires must be secured with cable ties.

Bridges, double crimp or parallel connections must be made if the specified PIN chambers are already occupied.

Required special tools

13 5 220

13 5 281

Contents

Section Page

1. Parts overview	4
2. Preparatory work	5
3. Installation	6
4. Programming and encoding engine control unit ECU (DME or EMS2K).....	9
5. Workshop certificate	10
6. Finsihing off	11
7. Form for workshop certificate	12

1. Parts overview

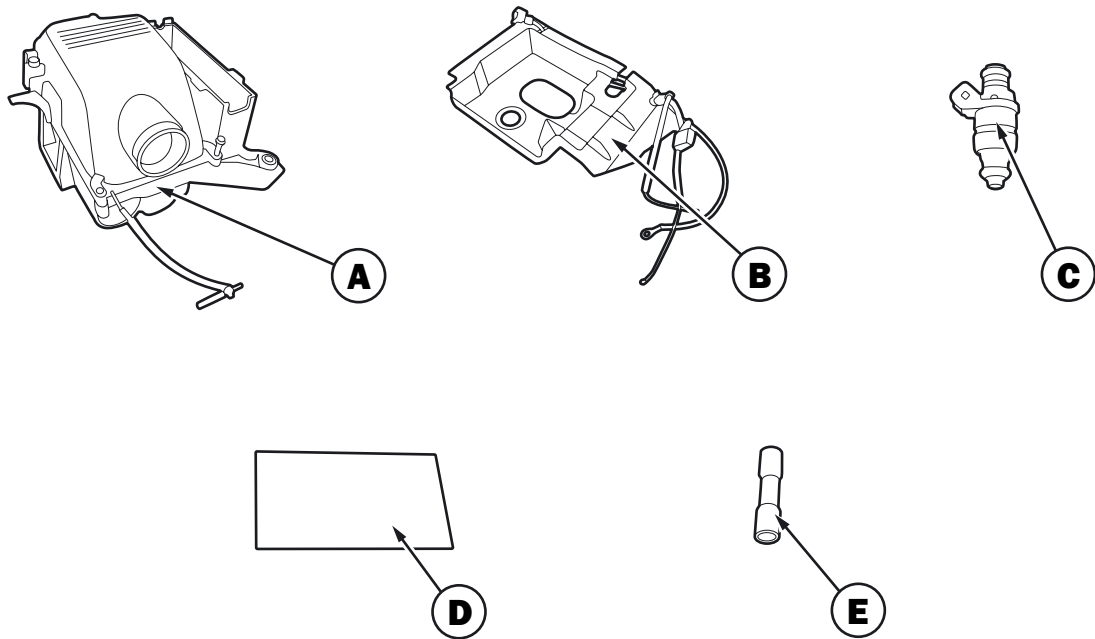

050 0553 V

Key

- A Air cleaner casing
- B Partition
- C Fuel injector nozzle
- D Heat shield
- E Crimp connector

2. Preparatory work

	TIS No.
Perform quick test	--
Disconnect negative terminal of battery	12 00 ...
Remove the following components	
Air cleaner	13 71 500
Fuel injector nozzles	13 64 541

3. Installation

▶ Install fuel injector nozzles C as per TIS No. 13 64 541. ◀

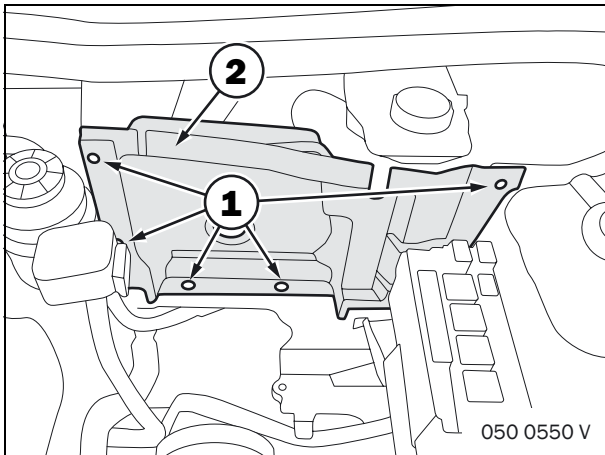

Undo bolts (1) and remove partition (2).

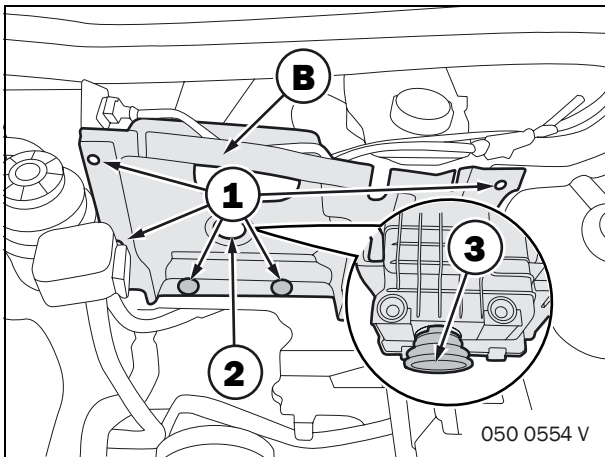

Secure partition **B** using the screws (1) from the standard partition.

Install air cleaner housing **A** in accordance with TIS No. 13 71 500.

▶ Make sure that the rubber element cover (3) closes off the lower intake opening (2). ◀

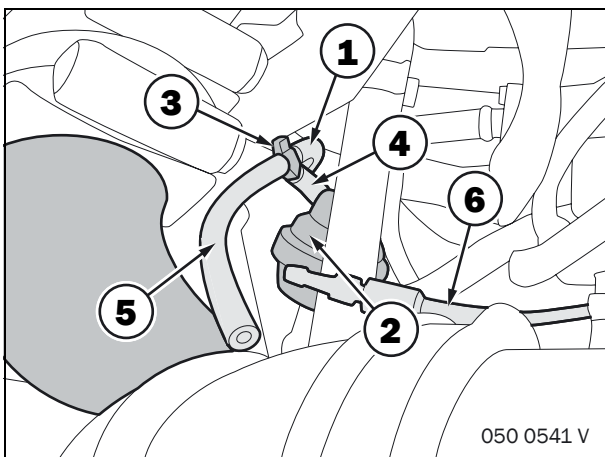

Detach hose from vacuum unit (2) on the compressor and connect to T-piece (3).

Connect hose (4) to vacuum unit (2).

Connect hose (5) to air cleaner (6).

3. Installation

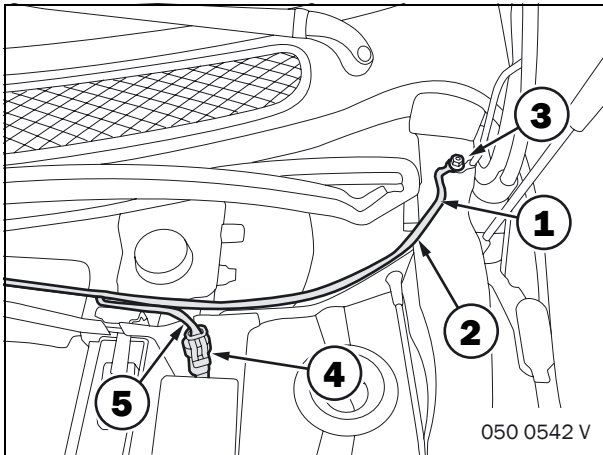

Pass black wire (1) from partition wiring harness **B** with cable lug through grommet (2) and connect at ground pin (3). Route cable (4) to recess (5).

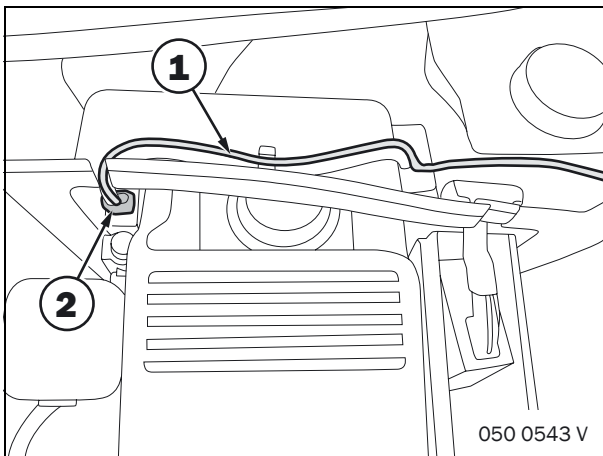

Route black wire (1) with 2-pin plug to the air cleaner and connect plug (2) to air cleaner.

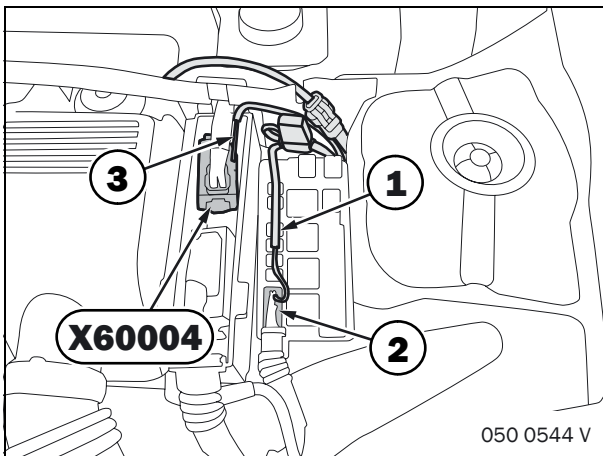

Route red wire (1) to fuse box and connect at PIN 8 of 12-pin connector (2). Fit cover to fuse box.

 If necessary cut cover of fuse box in order to be able to lead the wire out of the fuse box. ◀

Unplug connector **X60004** and remove connector housing.

Route yellow wire (3) to connector **X60004**.

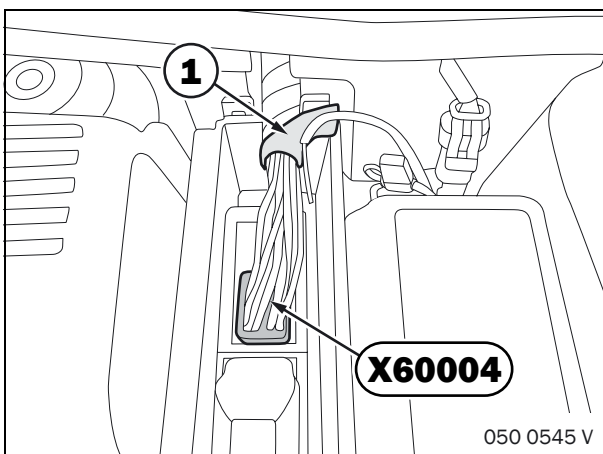

Remove the wrap (1) to approx. 60 mm.

Cut through white/red wire from PIN 113 at a distance of approx. 30 mm from connector **X60004** and strip insulation by 10 mm.

3. Installation

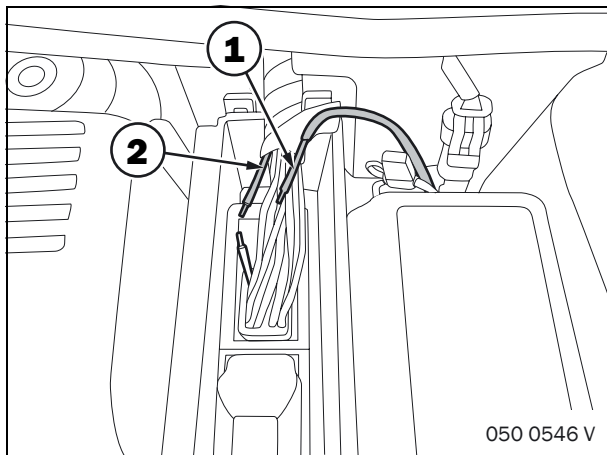

Connect (by twisting) yellow wire (1) to the one end (2) of the white/red wire.

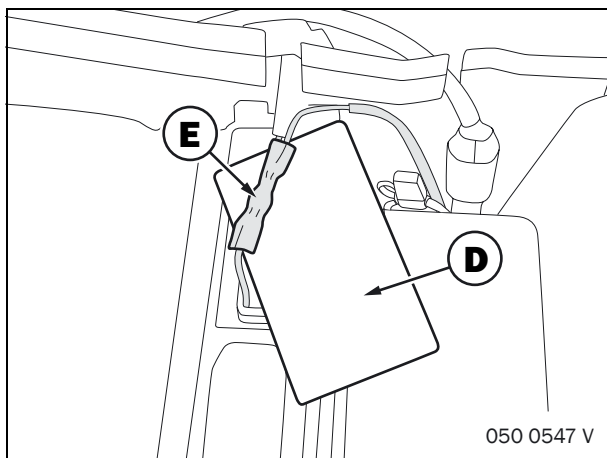

Connect white/red wire from connector and twisted wire with crimping pliers and crimp connector **E**. Make sure that the wires are connected correctly. Reconnect if necessary.

Fit heat shield **D** under crimp connector **E** to protect the plug and wires.

Use hot air blower to heat up crimp connector **E** until the adhesive it contains is released and the heat-shrinkable sleeve is firmly secured.

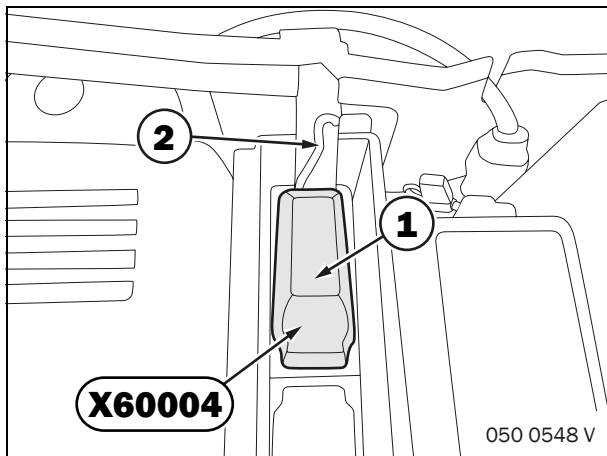

Fit connector housing (1) in position.

 The John Cooper Works software must be loaded before installing the engine control unit.

Make sure that the yellow wire (2) is not damaged. ◀

Reinstall seal on partition **B**.

4. Programming and encoding engine control unit ECU (DME or EMS2K)

 A DISplus or GT1 is necessary to program the engine control unit (DME).
The John Cooper Works data is on the CDs as from the 1st update CD33/36. Make sure that a battery charger is connected and there is a hard-wired connection between the radio head and tester.

Prior to programming, carry out a quick test and make sure there are no defects in the DME. ◀

Procedure

1. As the tester is already connected, you can directly select "Encoding/Programming".
2. Select option "5. DME Programming" in the "Encoding/Programming" menu.
3. Select "3. DME Programming".
4. Select "2. Replace Control Unit".
5. Select "1. Determine Control Unit".
6. The question as to whether the original DME is still installed in the vehicle now appears.
Answer this question with "NO".
7. Enter the "control unit number" of the DME (e.g. 7520019) via the user-prompted interface of the tester.
8. Enter the complete vehicle identification number (17 characters from the DME identification page).
9. Enter the assembly number (programmed control module number)
for the John Cooper Works upgrade kit as follows:

Software for DME				As from CD 39.0	As from CD 39.2	
		Model		Version	Part number	Part number
up to 07/04	before TÜ	R53		ECE	7547868	
				SAE	7547870	
as from 07/04	after TÜ	R53 TÜ	EMS 2	ECE	7547878	
				SAE	7547880	
			EMS 5150	ECE		7550278

10. Ignore the list of alternative numbers. The definition stage is now completed and all necessary data have been saved in the tester. Now press the arrow keys to exit this section.
11. Select "2. Program Basic Control Unit".
12. Enter the last 7 characters (2 letters, 5 digits) of the vehicle identification number in order to identify the correct data.
13. The message indicating that programming may take 4 - 12 minutes now appears.
Press arrow keys to continue.
14. Enter the current kilometre reading of the car.
15. Start the automatic programming procedure.
16. After programming, the tester will automatically set the DME to the electronic vehicle immobilizer (EWS).

 If the system informs you at this point that the EWS control unit requires encoding, proceed as described in the following.

A. Turn terminal 15 to OFF and disconnect the battery for 3 minutes.

B. Reconnect the battery and turn terminal 15 to ON. ◀

17. Select ZCS/FA encoding.
18. Select "New Coding" followed by "Motronic" and carry out renewed encoding of the Motronic (DME).
In this way, the systems (e.g. air conditioning) installed in the vehicle are identified so that they can be controlled via the DME.
19. After the prompt to do so, turn off the ignition and wait until the specified time interval has elapsed.
Restart the car.
20. Now perform a quick test and clear the fault codes logged as the result of the programming procedure.

5. Workshop certificate

WORKS

Werkstatt-Bescheinigung

Hiermit wird bestätigt, dass an dem nachfolgend genannten Fahrzeug der John
Coper Works Baumgärtli 11 12 0 302 8739 komplett verbaut wurde. Im einzelnen
wurden folgende Komponenten umgesetzt:

1. Steuerung mit Softwarestand JCM
2. Kompressor 01 66 0 39 354
3. Zylinderkopf JCM (M3025)
4. Einsteckabdeckung JCM (M31 087475)
5. Zündkerzen NGK BKRT50QP

Fahrzeugtyp: MHD Cooper S (R33)
 Fahrzeug-Kenn-Nr.:
 Fahrzeugführer Name u. Nachname:

Ort, Datum:

Unterschrift der verantwortlichen Person:
 Kfz-Werkstatt (Stempel):

050 0558 V

 The workshop certificate is an integral part of the installation instructions (see Chapter 7, form for workshop certificate). ◀

Enter the last seven digits of the vehicle identification number, the name and address of the vehicle owner in the box marked (2). Enter the place, date and signature of the installer, company name and stamp of the specialist workshop in the box marked (3).

 The workshop certificate (1) should be presented together with the certificate to the registration authority. ◀

6. Finishing off

- Reassemble vehicle in reverse order of removal.
- Reconnect battery
- Perform quick test
- Perform function test

Increase the engine speed to more than 4500 rpm in order to check the second flap of the air cleaner. The flap should open. The flap should close again at an engine speed below 4000 rpm.



Workshop certificate

This certificate confirms that the John Cooper Works Upgrade Kit (11 12 0 395 131) has been installed in full on the vehicle specified below.

The following components have been modified:

1. Fuel injector nozzles 13 53 0 391 511
2. Air cleaner housing with filter element 1WSB - RA091 - AA
3. Control unit with John Cooper Works software status

Vehicle type: MINI Cooper S (R53)
MINI Cooper S Convertible (R52)

Vehicle identification No.: _____

Vehicle owner: Name and address: _____

Place, date

Signature

The combination of the John Cooper Works Tuning Kit 200 bhp (11 12 0 302 673 or 11 12 0 303 287) and of the Upgrade Kit (11 12 0 395 131) corresponds to the John Cooper Works Tuning Kit 210 bhp (11 12 0 395 128, 11 12 0 395 129, 11 12 0 395 130). ◀