

2007 Mini Cooper Installation Instructions

Serial Number

Please read BOTH these Installation Instructions and the General Towing Instructions before attempting to install or operate this equipment.

1. Blue Ox® towing products and accessories are intended to be installed by Blue Ox® Dealers who are familiar with our products and have the equipment and knowledge to do “fit work.” When necessary, Blue Ox® Dealers can be found at www.blueox.us or by contacting our 24/7 Customer Care Department at (888) 425-5382.

Attachment Tab Height: 13.5”
Attachment Tab Width: 22”

2. Many Blue Ox® Baseplates are designed to use existing holes and hardware to mount the baseplate to the towed vehicle. Even though bolts are there, do not assume they are adequate for baseplate mounting. Always use hardware supplied in the hardware kit or existing hardware specified in the Baseplate Towing Installation Instructions.

Bolt Torque Specifications

Torque in Foot-Pounds per Metric Bolts

Bolt Size	Grade 8.8	Grade 10.9
6MM	6	8
8MM	16	22
10MM	31	40
12MM	54	70
14MM	89	117

Confirm the towability and pre-towing procedures for your vehicle with the owner’s manual or contact the vehicle’s manufacturer for specific towing procedures. You can also contact REMCO for additional information at 1(800)228-2481.

Bolt Torque Specifications

Torque in Foot-Pounds per Inch Bolts

Bolt Size	Grade 5	Grade 8
1/4”	10	14
5/16”	19	29
3/8”	33	47
7/16”	54	78
1/2”	78	119
5/8”	154	230



WARNING

Failure to read and follow these instructions could result in separation of the towed vehicle from the tow bar, causing property damage, loss of towed vehicle, personal injury or death.

BX1304

2007 Mini Cooper

Installation Instructions

Parts List

Ref. No.	Qty.	Part #	Description
1	1	61-6393	Weldment, Baseplate, BX1304
2	8	61-5208	Weldment, Nut Plate, 1/4 x 1 x 1, 3/8"
3	8	201-0368	3/8-16 x 1 1/4" Hex Head Bolt, Grd. 5, ZP
4	10	203-0010	3/8" Lock Washer, ZP
5	4	203-0003	3/8" Flat Washer, ZP
6	2	201-0419	8MM-1.25 x 50MM Hex Bolt, Grd. 8.8, ZP
7	2	201-0553	1/4-20 X 1/2" Hex Washed Type F, ZP
8	2	201-0192	#10-32 x 1/2" Slot, Round Head Screw
9	2	203-0054	#10 Lock Washer
10	2	202-0047	#10-32 Hex Nut
11	2	101-5822	Adapter, 4 Way Connector
12	2	62-3468	Attachment, Assembly, SF/SB, 1 Hole
13	2	102-6816	Backing Plate, BX1304
	2	290-0437	Cap Plug, Black (not shown)
	4	229-0359	Quicklink, 3/8", ZP (not shown)
	2	226-0046	Baseplate Safety Cable, 36" Class III (not shown)

Tools Required

Flat Screwdriver	9/16" Socket
10MM Socket	17MM Socket
13/32" Drill Bit	1 1/4" Hole Saw
Loctite RED	

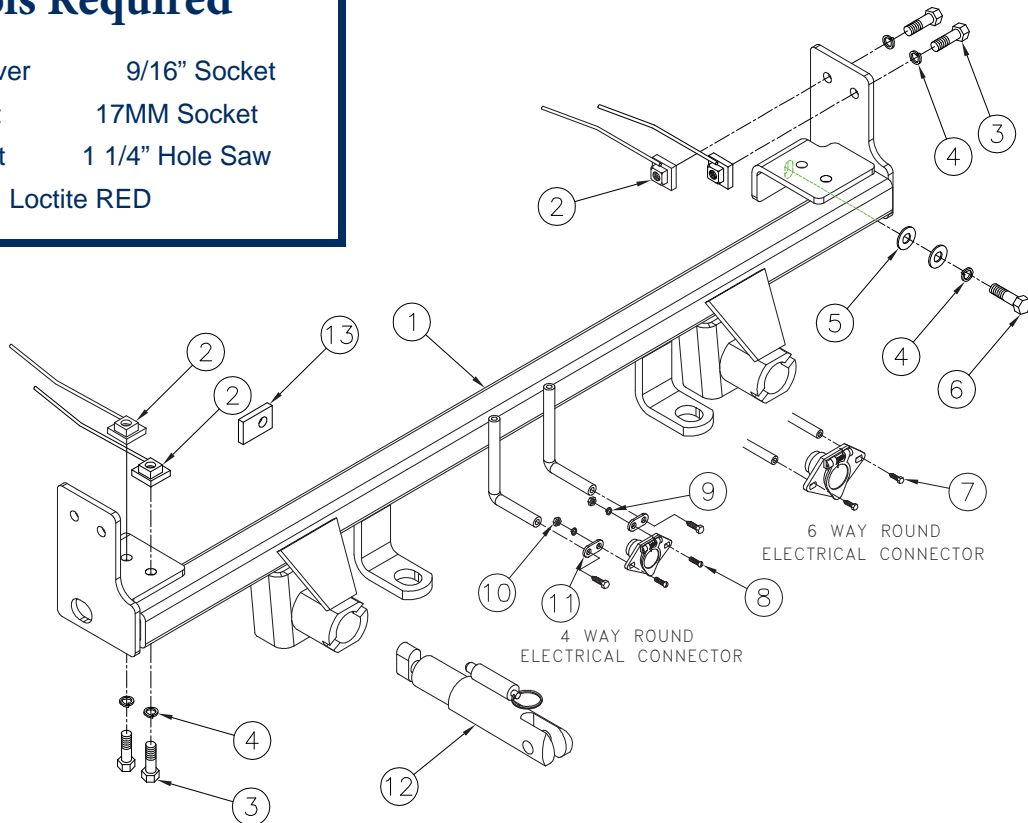

Important:

Use only genuine factory replacement parts on your baseplate. Do **NOT** substitute homemade or non-typical parts. If a bolt is lost or in need of replacement, for your safety and the preservation of your baseplate, be sure to use a replacement bolt of the same grade (In most cases it will be Grade 5, please reference the parts list above). Replacement parts may be ordered through your nearest Blue Ox® Dealer or Distributor.

BX1304
2007 Mini Cooper
Installation Instructions

Vehicle Weight:

The weight of this vehicle is near the Class III, 5,000 lb. rating limitations. Some models, depending on options, may well exceed this 5,000 lb. rating. Be sure to confirm the weight of your individual vehicle before towing. As of 1999, the Aventa® II is now 10,000 lbs. and either the Aventa® II or the Aventa® LX tow bar must be used for these applications.

Tow Bar Adapters are NOT to be used with vehicles weighing over 5,000 lbs.

Installation Notes: The fascia metal bumper and air baffle are removed and reinstalled during installation of the baseplate. Drilling is required. Trimming of the fascia is required.

The dimensional variations between otherwise identical vehicles can be considerable. While the baseplate was designed for easy installation, it may be necessary to tailor the baseplate slightly to compensate for auto manufacturer's tolerances. These minor adjustments may include filing a hole slightly, bending electrical rods and/ or bending end plates.

The BX8848 Diode Wiring Kit is recommended for this vehicle.

Installation Instructions:

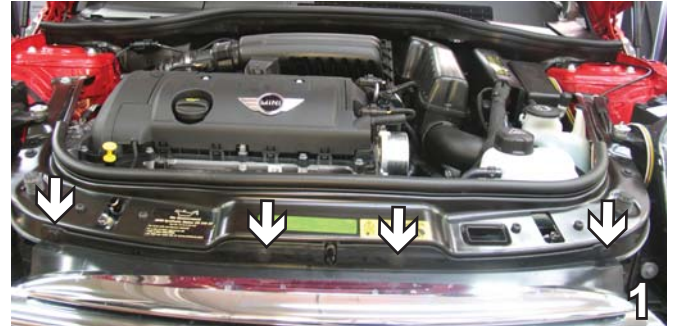

1. Using a flat screwdriver, remove four pushpins on top edge of grille. Set push pins aside to be reinstalled later.



2. Forward the front tire, there are two pushpins that need to be removed. Do this to both sides. Use a flat screwdriver and set aside for later reinstallation.



3. After removing the wheel well cover, remove one pushpin connecting the fascia using a flat screwdriver. Also remove the small yellow light (gray arrow). Do this to both sides. Set pushpins aside for later reinstallation.

BX1304

2007 Mini Cooper

Installation Instructions

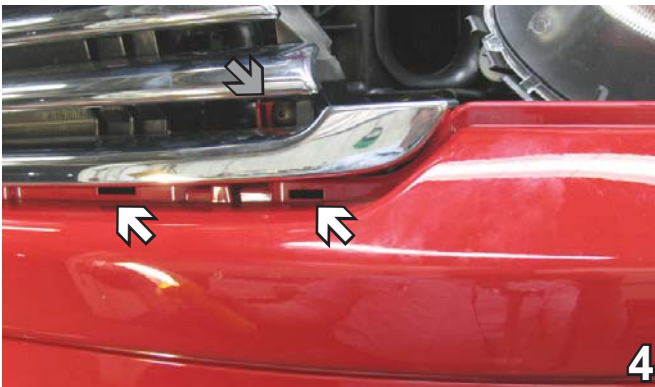

4. Remove the grille by starting from the side and releasing the clips. They will fit back in when reinstallation occurs. By the wheel well there is a bolt that needs to be removed with a 10MM socket. Also, after removing the grille, there are two bolts that need to be removed with a 10MM socket. (gray arrow) Do to both sides and set aside for later reinstallation.

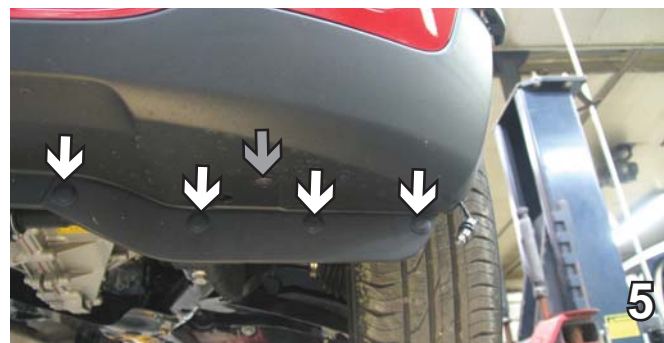

5. Remove four pushpins from the edge of the bottom of the fascia on both sides. There is also a torque 25T bolt (gray arrow) to be removed from both sides using a torque wrench. There are three other pushpins in the center, remove them. Eyebolts need to be removed from the fascia to remove the fascia. Pull the fascia forward, disconnect side running and fog lights. Set aside for later reinstallation.

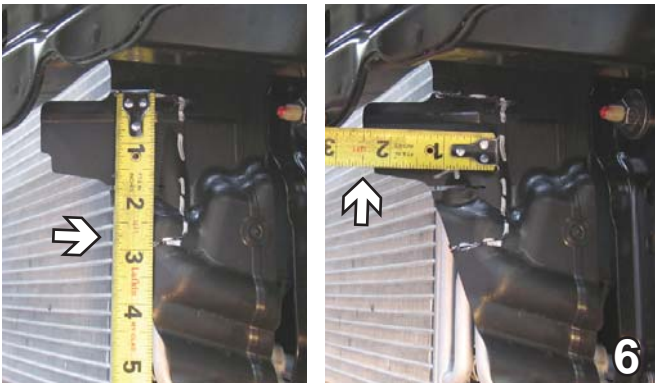

6. You will need to cut the air dams 3" down and 2.5" in to make room for the baseplate. Do this to both sides. These will not be reinstalled.

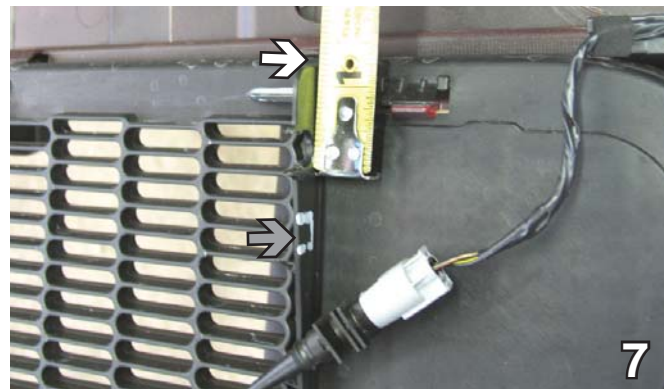

7. Located on both sides behind the grill, there is a temperature sensor that will need to be moved. Trim 1 1/8" from the top to remove the notch holding the sensor, cut and remove the webbing with it, and replace the sensor in another notch we will cut out a little further down (gray arrow).

BX1304
2007 Mini Cooper
Installation Instructions

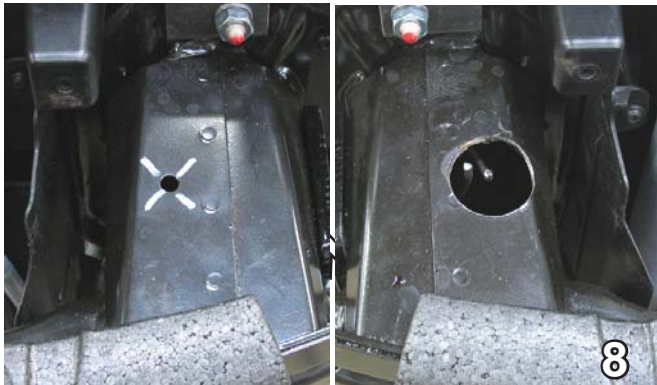

8. Using an existing hole on top of the metal bumper drill a hole using a 1 1/4" hole saw to cut opening for front end to install nut plates. Do this on both sides.

Using a good quality paint, spray cut edges of frame to prevent rusting.

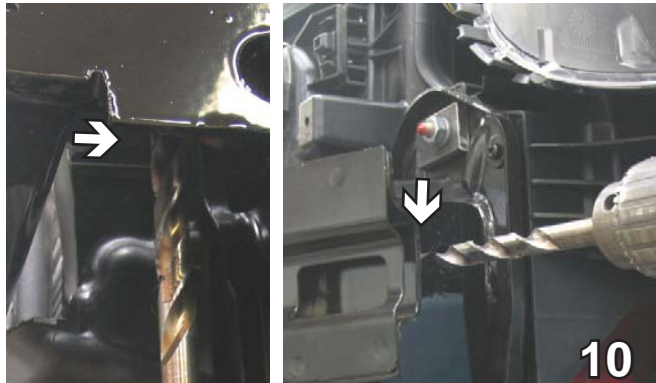

10. Using the baseplate as a template, drill two holes underneath the baseplate and two holes on the side. Do this to both sides using a 13/32" drill bit.

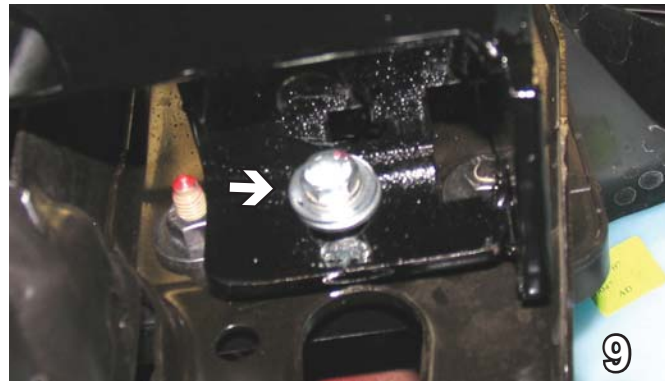

9. Hold the baseplate up in place and start the 8MM-1.25 x 50MM hex bolt with lock and two flat washers into existing hole. Do to both sides of the vehicle. Clamp the baseplate in place.

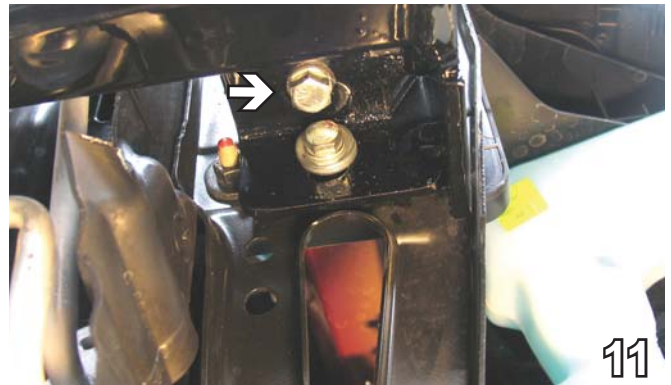

11. Insert 3/8-16 x 1 1/4" bolts with Loctite, 3/8" lock washers and 3/8" nut plates into the drilled holes on the bottom. Do this on both sides.

BE SURE TO USE LOCTITE® RED ON ALL BOLTS BEFORE TIGHTENING. TIGHTEN ALL BOLTS ACCORDING TO THE TORQUE CHART ON THE FRONT PAGE OF THESE INSTRUCTIONS OR ON PAGE 3 OF THE BASEPLATE TOWING GENERAL INSTRUCTIONS.

BX1304
2007 Mini Cooper
Installation Instructions

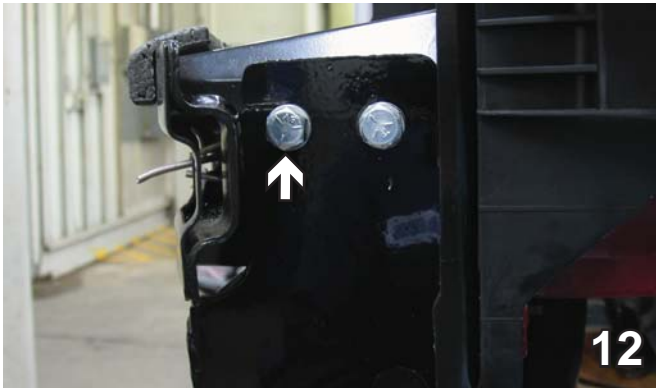

12. Into the holes drilled in the side also insert 3/8-16 x 1 1/4" bolts with Loctite, 3/8" lock washers and 3/8" nut plates. Do this on both sides.

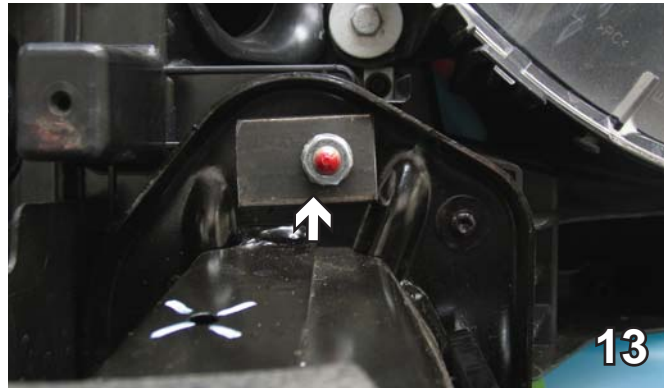

13. On top of bumper, remove nut and replace with 1" x 1.5" nut with Loctite applied. The hole is located 1" in, and you will need one for both sides.



14. The wire air sensor needs to be moved behind the fog light. It originally was placed around the top of the fog light (gray arrows) and needs to be placed and taped below the fog light. Cut off a clip and tape to the sensor below the fog light.



15. The photo above shows recommended installation of the cables to frame of vehicle. If vehicle has additional options (not shown above) which interfere with mounting permanent baseplate safety cables, secure the cables to a solid piece of the vehicle frame as described in instructions included with the permanent baseplate safety cables.

16. Hold the fascia up to its original location. Mark and cut the fascia just on the outside edges of the receiver tube and convenience links. Do this to both sides of the vehicle.

BX1304
2007 Mini Cooper
Installation Instructions



Be sure that **ALL** electrical connections are plugged in properly and functioning **BEFORE** installing the fascia.

Customer Service Commitment

Blue Ox® is focused on providing exemplary customer service, as observed in our mission statement and guiding principles. In accordance with this objective, Blue Ox® is proud to provide services such as repairs and general maintenance of Blue Ox® products at over 150 RV Rallies. Look for our Destination America or Blue Ox® Racing service crews at the next rally or race that you attend. If you were not present, you will find an informative, personalized note explaining any services that may have been performed to your Blue Ox® products.

Blue Ox® also offers educational seminars at rallies and through our Park and Resort teams. In addition, Blue Ox® customers visiting our factory may take advantage of the well-equipped Blue Ox® RV park at no charge to you, our valued and appreciated customer.

DEALER or INSTALLER:
Be certain the user receives the instruction sheets for their products.



© 2007 Blue Ox
One Mill Road, Industrial Park
Pender, Nebraska 68047
Phone: (402) 385-3051 • Fax: (402) 385-3360
www.blueox.us
7/14/08