

# Original MINI Accessory. Installation Instructions.



## Retrofit additional headlights

**MINI ONE (R56)**  
**MINI COOPER (R56)**  
**MINI COOPER S (R56)**

### Retrofit Kit No.:

63 12 0 417 885	Retrofit additional headlights black US
63 12 0 420 292	Retrofit additional headlights chrome US
63 13 0 422 704	Supplementary kit, front centre grille, Cooper S
63 13 0 422 706	Supplementary kit, front centre grille, Cooper S with aerodynamics package SZ
63 13 0 422 707	Supplementary kit, front centre grille, Cooper chrome
63 13 0 422 708	Supplementary kit, front centre grille, Cooper S with aerodynamics package SZ
63 13 0 427 567	Supplementary kit, front centre grille, MINI Diesel
63 13 0 427 568	Supplementary kit, front centre grille, MINI One
63 13 0 427 569	Supplementary kit, front centre grille, Cooper with aerodynamics package SAZ

### Installation time

The installation time is **approx. 1.25 hours**. This may vary depending on the condition of the car and the equipment in it.

### Important information

These installation instructions are primarily designed for use within the MINI dealership organisation and by authorised MINI service companies.

In any event the target group for these installation instructions is specialist personnel trained on MINI cars with the appropriate specialist knowledge.

All work must be completed using the latest MINI repair manuals, circuit diagrams, servicing manuals and work instructions, in a rational order, using the prescribed tools (special tools) and observing current health and safety regulations.

**In the event of any installation or function problems, restrict the troubleshooting session to about 0.5 hours for mechanical work or 1.0 hour for electrical work.**

In order to reduce costs and avoid any additional expense, send a query immediately to the Technical Parts Support via the Aftersales Assistance Portal (ASAP).

Specify the following information:

- Chassis number
- Part number of the retrofit kit
- A precise description of the problem
- Work steps already carried out

### Pictograms



Denotes instructions that draw your attention to dangers.



Denotes instructions that draw your attention to special features.

◀ Denotes the end of the instruction or other text.

**Print out the "Customer information" chapter at the end of the installation instructions and give it to the customer.**

Do not archive the hard copy of these installation instructions since daily updates are made by ASAP!

## **Installation information**

The front centre grille is to be removed and replaced with the new front centre grille **C** with cut-out for holder. No modifications are required for cars with front centre grille in honeycomb or array design without chrome. The chrome trim in the new front centre grille **C** must be modified for cars with front centre grille in array design chrome.

All pictures show LHD cars; proceed accordingly on RHD cars.

Ensure that the cables and/or lines are not kinked or damaged as you install them in the car. The costs thereby incurred will not be reimbursed by BMW AG.

Additional cables/lines that you install must be secured with cable ties.

## **Ordering instructions**

The following parts are not supplied in the retrofit kit and must be ordered separately (see EPC for part number and details).

- Supplementary kit, front centre grille (contains centre front grille **C**, holder left **E** and holder **F** right)
- Driver's side knee protection **Q**

## **Special tools required**

None

## Contents

Section	Page
1. Parts list .....	4
2. Preparatory work .....	5
3. Connection diagram .....	6
4. Installation and cabling diagram .....	7
5. To install and connect the cable kit .....	8
6. To install the additional headlight holders .....	11
7. To modify the front grille and install the additional headlights .....	12
8. Concluding work and coding .....	13
9. Circuit diagram .....	14
10. Customer information for the additional headlights .....	16

## 1. Parts list

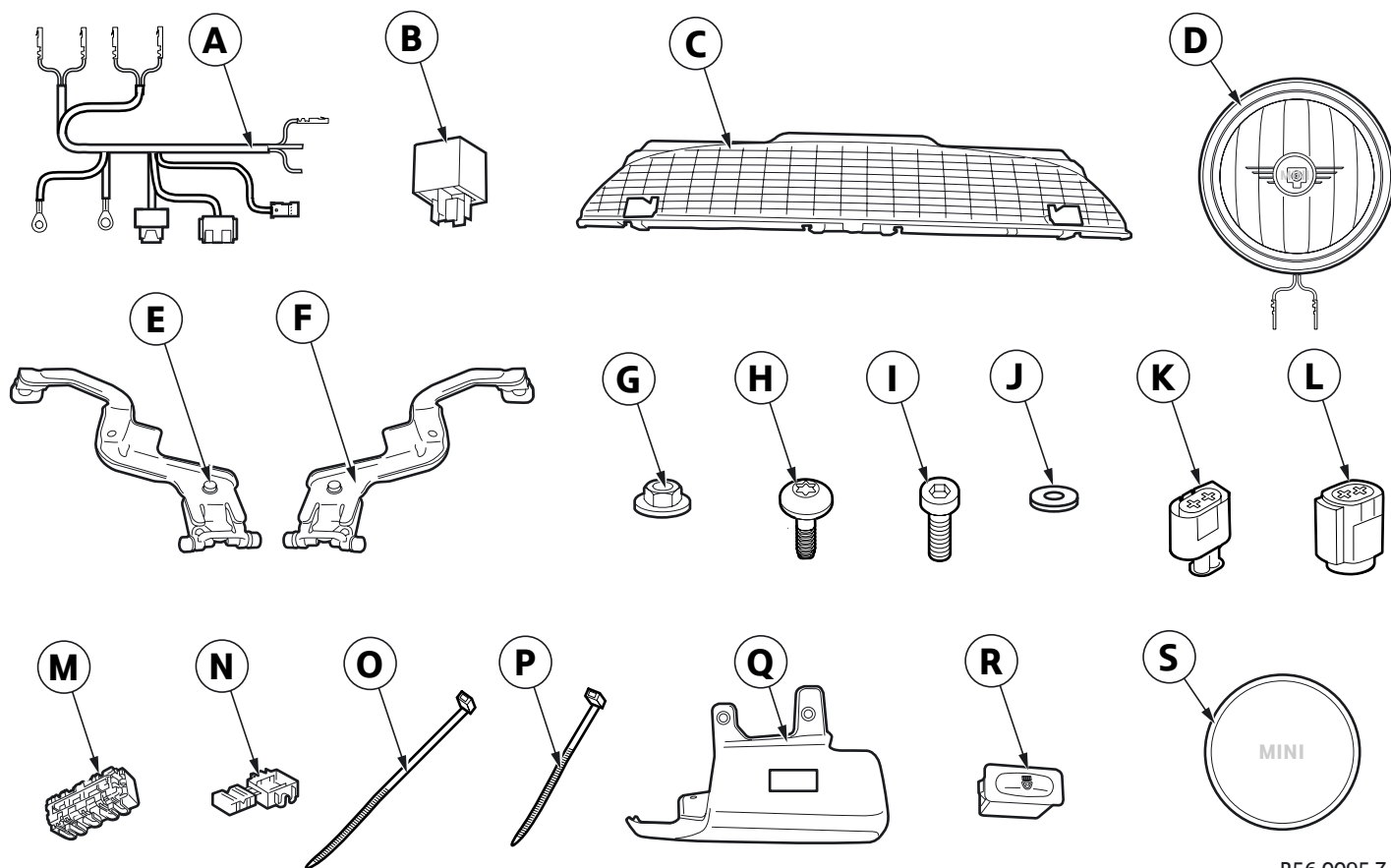

R56 0095 Z

### Legend

- A** Cable kit
- B** Control module
- C** Front centre grille (not supplied with the retrofit kit)
- D** Additional headlights (2x)
- E** Left bracket (not supplied with the retrofit kit)
- F** Right bracket (not supplied with the retrofit kit)
- G** Hexagonal nut M8, self-locking (2x)
- H** Screw M6 (2x)
- I** Screw M6 (4x)
- J** Washer M6 (3x)
- K** Black 2-pin socket casing (2x)
- L** Black 2-pin plug casing (2x)
- M** 5-way miniature connector (1x)
- N** 2-way miniature connector (2x)
- O** Cable tie 445 x 4.8 mm (2x)
- P** Cable tie 200 x 3.6 mm (25x)
- Q** Knee protection, driver's side (not supplied with the retrofit kit)
- R** Button
- S** Headlight cover (2x)

## 2. Preparatory work

	<b>TIS No.</b>
Conduct a brief test	---
Disconnect negative pole of battery	12 00 ...
<b>The following components must be removed first of all</b>	
Centre front grille (no longer required)	51 13 000
Trim on front centre grille (fit on new grille)	51 13 003
Trim at the bottom left of the instrument panel	51 45 180
Knee protection, driver's side (US cars only, no longer required)	51 45 250
Front left door sill strip	51 47 000
Windscreen panel cover, left	51 13 123
Windscreen panel cover, right	51 13 124

### 3. Connection diagram

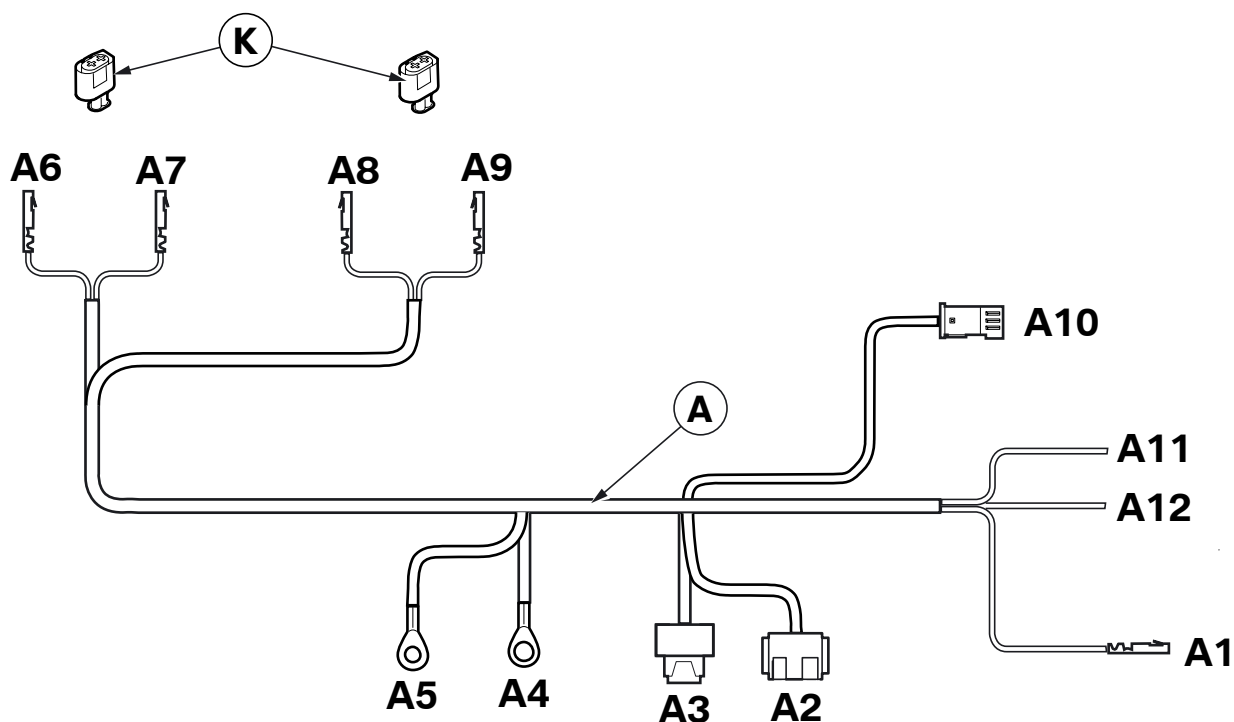

R56 0097 Z

Branch/Item	Designation	Signal	Cable colour/ Cross-section	Connection location in car	Abbreviation/ Slot
A	Cable kit	---	---	---	---
A1	Socket contact	Terminal 56a	GE/BL 0.75 mm <sup>2</sup>	<b>Cars without Xenon lights only</b> With miniature connector <b>M</b> to GE/BL cable from footwell module <b>Cars with Xenon lights only</b> Insert in footwell module	X14260 PIN 4  X14260 PIN 4
A2	9-pin relay socket SW	---	---	To control module <b>B</b>	---
A3	Fuse holder	---	---	---	---
A4	Eyelet M6	Terminal 31	BR	Service point terminal 31 under engine compartment fuse holder	X165
A5	Eyelet M8	Terminal 30	RT/BL 2.5 mm <sup>2</sup>	Service point terminal 30 under fuse holder, engine compartment	X2
A6	Socket contact	FSL	BL/RT 1.0 mm <sup>2</sup>	With socket casing <b>K</b> on plug casing <b>L</b> of the left additional headlight <b>D</b>	PIN 1
A7	Socket contact	Terminal 31 L	BR 1.0 mm <sup>2</sup>	With socket casing <b>K</b> on plug casing <b>L</b> of the left additional headlight <b>D</b>	PIN 2
A8	Socket contact	FSR	BL/WS 1.0 mm <sup>2</sup>	With socket casing <b>K</b> on plug casing <b>L</b> of the right additional headlight <b>D</b>	PIN 1
A9	Socket contact	Terminal 31 L	BR 1.0 mm <sup>2</sup>	With socket casing <b>K</b> on plug casing <b>L</b> of the right additional headlight <b>D</b>	PIN 2
A10	White 4-pin socket casing	---	---	To pushbutton <b>R</b>	---
A11	Cable open	Terminal 58g	GR/RT 0.5 mm <sup>2</sup>	With miniature connector <b>N</b> to GR/RT cable from footwell module	X14261 PIN 48
A12	Cable open	Terminal 15	GR 0.75 mm <sup>2</sup>	With miniature connector <b>N</b> to GR cable from footwell module	X14261 PIN 12

## 4. Installation and cabling diagram

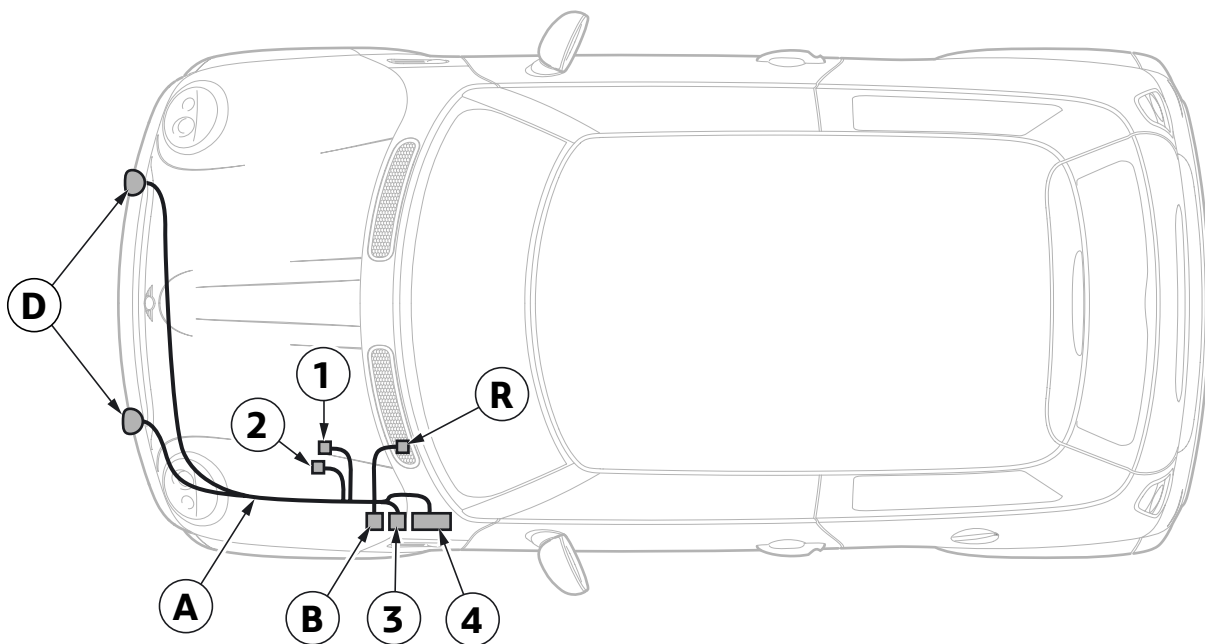

R56 0120 Z

### Legend

- A** Cable kit
  - B** Control module
  - D** Auxiliary headlights
  - R** Pushbutton (not for US cars)
- 
- 1** Tap terminal 30 on service point terminal 30, **X2**
  - 2** Tap terminal 31 on service point terminal 31, **X165**
  - 3** Fuse holder **A3**
  - 4** Footwell module, socket casing **X14260**

## 5. To install and connect the cable kit

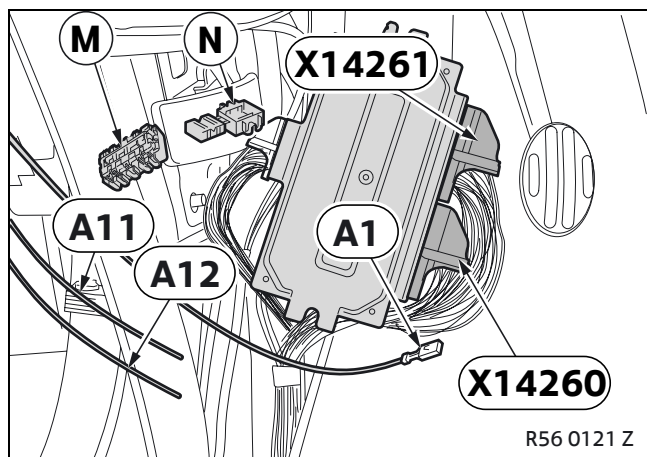

Release footwell module (1) and socket casing **X14260** (51-pin SW/GR).

▶ **The socket casings from X14260 and X14261 are both black, the interior casing of the X14260 is grey.** ◀

Connect branch **A1** as follows to socket casing **X14260**:

### Cars without Xenon lights only

- Connect branch **A1**, GE/BL cable, using 5-way miniature connector **M** to GE/BL cable from PIN 4

### Cars with Xenon lights only

- Connect branch **A1**, GE/BL cable, to PIN 4

### All cars

Connect branches **A11** and **A12** using 2 miniature connectors **N** to the socket casing **X14261** as follows:

- Branch **A11**, GR/RT cable, to GR/RT cable from PIN 48
- Branch **A12**, GR cable, to GR cable from PIN 12

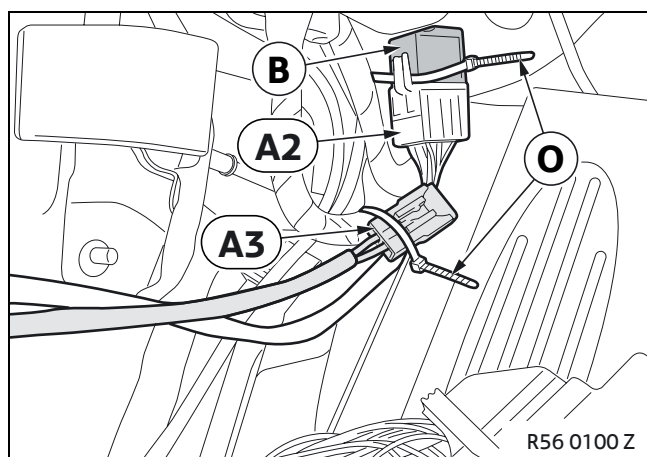

▶ Failure to observe the electrostatic discharge (ESD) instructions according to TIS RA 61 35 can result in damage to the control unit **B**. ◀

Plug control unit **B** into branch **A2** (9-pin relay socket).

Attach branch **A2** and branch **A3** (fuse holder) with cable ties **O** to vehicle wiring harness in footwell on driver's side.

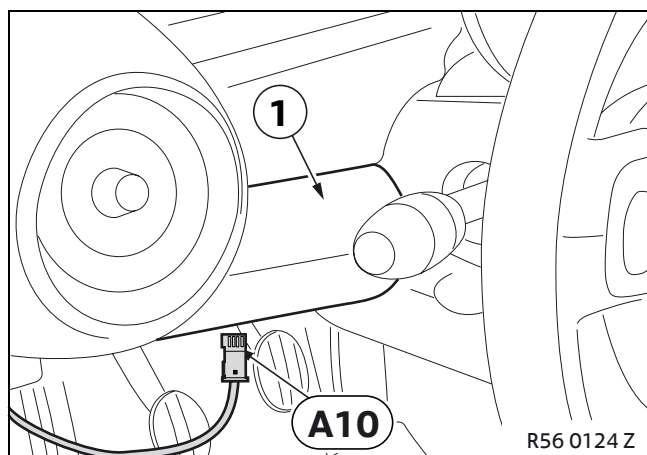

Remove the knee protection on driver's side (1) (no longer required).

Route branch **A10** (4-pin WS socket casing) to the mounting location of the driver's side knee protection (1).

## 5. To install and connect the cable kit

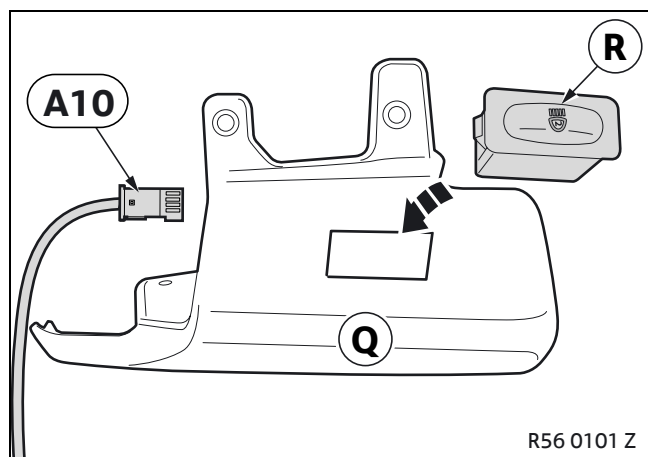

Insert pushbutton **R** into driver's side knee protection **Q** as shown.

Connect branch **A10** (4-pin WS socket casing) on pushbutton **R** and fit driver side knee protection **Q**.

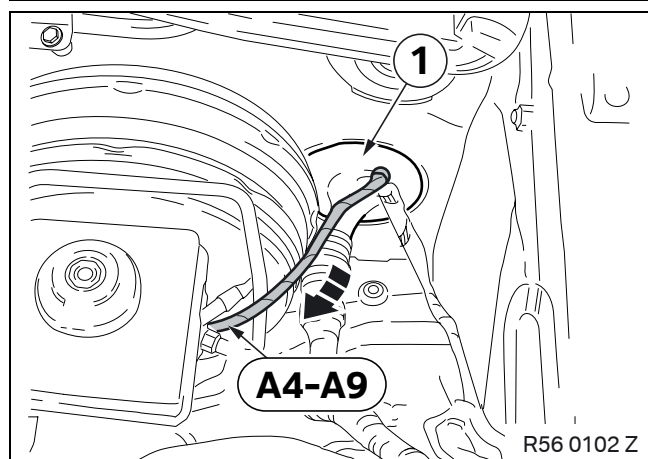

Route branches **A4-A9** from the inside of the car through rubber grommet (1) into the engine compartment.

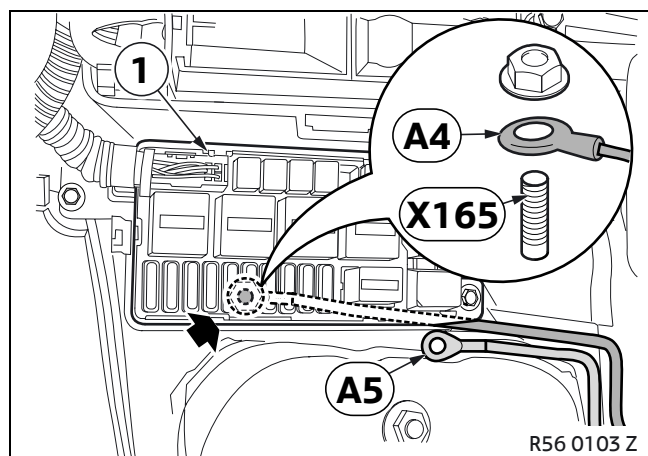

Route branches **A4-A5** to the fuse holder in engine compartment (1).

Unscrew the engine compartment fuse holder (1) and fold it back.

Screw branch **A4** (eyelet M6) to service point terminal 31 **X165**.

Screw the engine compartment fuse holder (1) back into place.

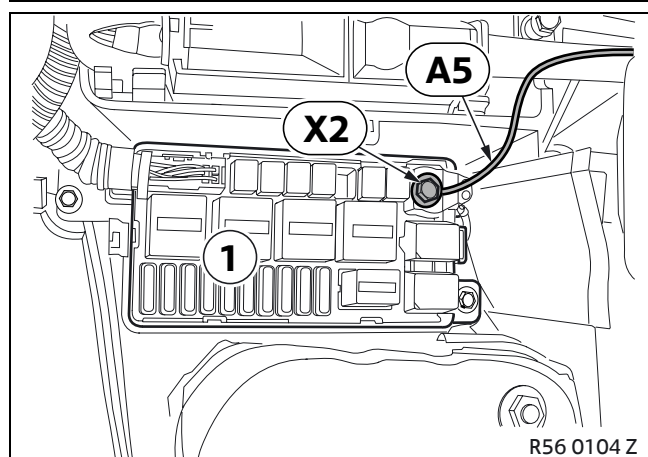

Screw branch **A5** (M8 eyelet) to service point terminal 30 **X2** of the engine compartment fuse holder (1).

## 5. To install and connect the cable kit

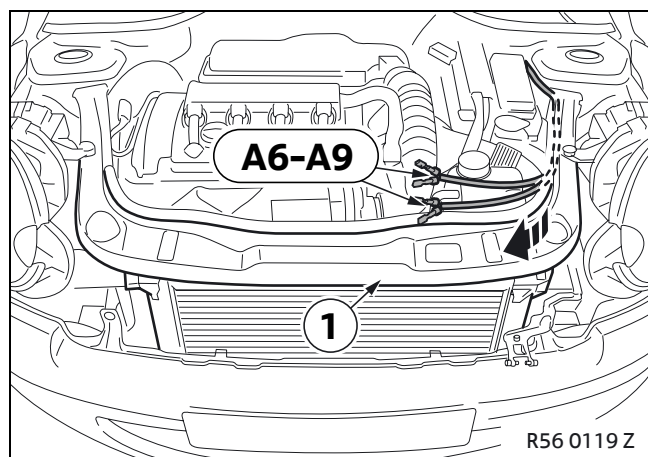

Route branches **A6-A9** along the standard wiring harness to the front panel (1).

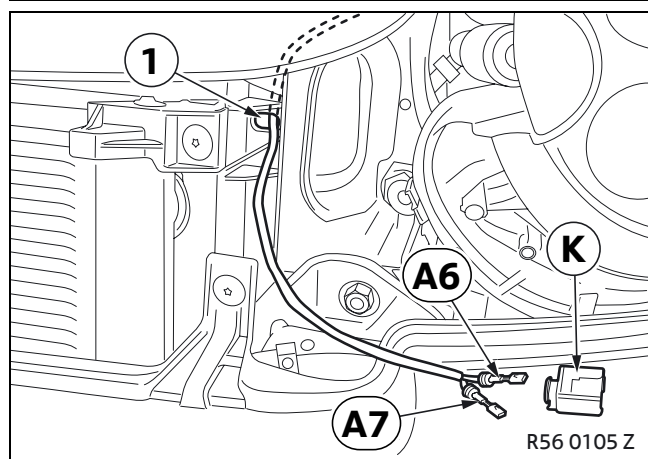

Route branches **A6-A7** through the opening (1) in the front panel.

Connect branches **A6** and **A7** as follows to socket casing **K** (2-pin SW):

- Branch **A6**, BL/RT cable, to PIN 1
- Branch **A7**, BR cable, to PIN 2

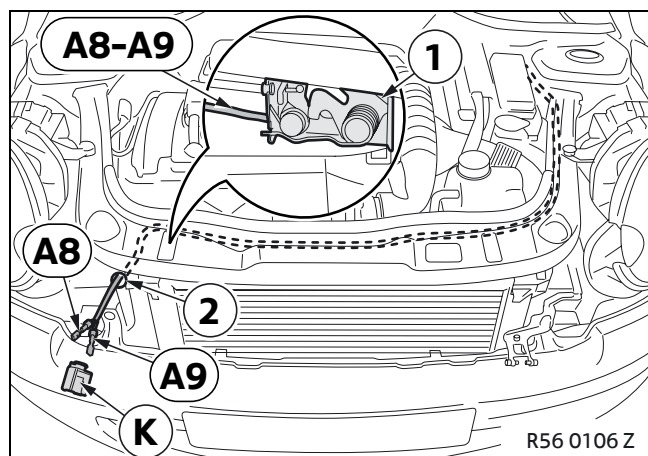

Route branches **A8-A9** along the bonnet closing panel and through the opening (2) in the front panel.

▶ Make sure the bonnet catch (1) is not trapped. Branches **A8-A9** must not be damaged by the bonnet catch (1). ◀

Connect branches **A8** and **A9** as follows to socket casing **K** (2-pin SW):

- Branch **A8**, BL/WS cable, to PIN 1
- Branch **A9**, BR cable, to PIN 2

## 6. To install the additional headlight holders

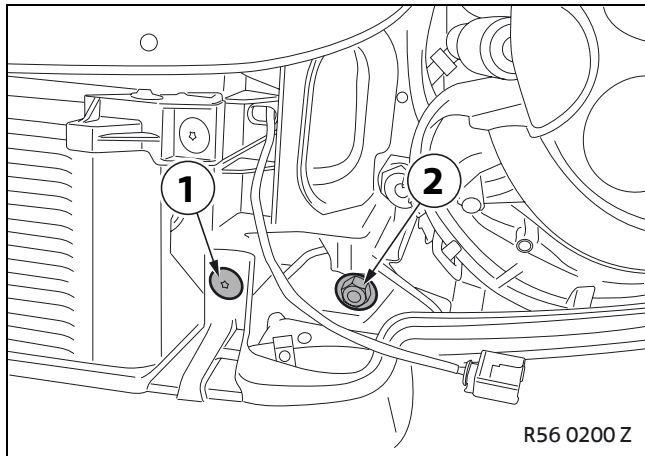

Undo bolts holding bumper trim (1) and support (2) to vehicle and discard.

Proceed in exactly the same way on the right-hand side.

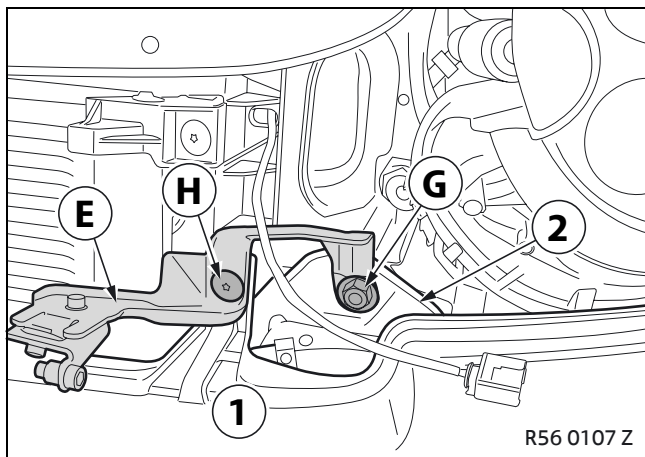

 The tightening torque of the hexagonal nut **G** is 22 Nm. ◀

Secure the left-side holder **E** using hexagonal nut **G** and bolt **H**.

Carry out same procedure for right-side holder **F**.

## 7. To modify the front grille and install the additional headlights

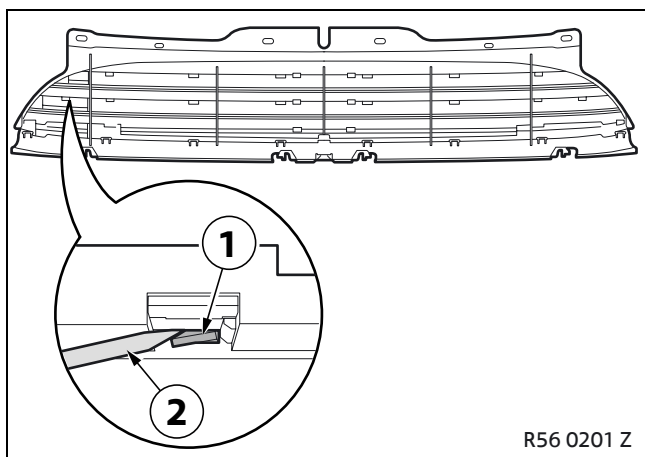

### Cars with front grille in chrome only

▶ To prevent any damage to the chrome trim, place the front centre grille (1) on a protective cover. ◀

Use a screw driver (3) to remove the glue from the retaining lugs (2).

▶ Carefully push the retaining lugs (2) downwards and remove the chrome trim from the front grille (1). ◀

Clip the chrome trim into the new front centre grille C.

Use adhesive (Sika-Flex) to secure the retaining lugs (2).

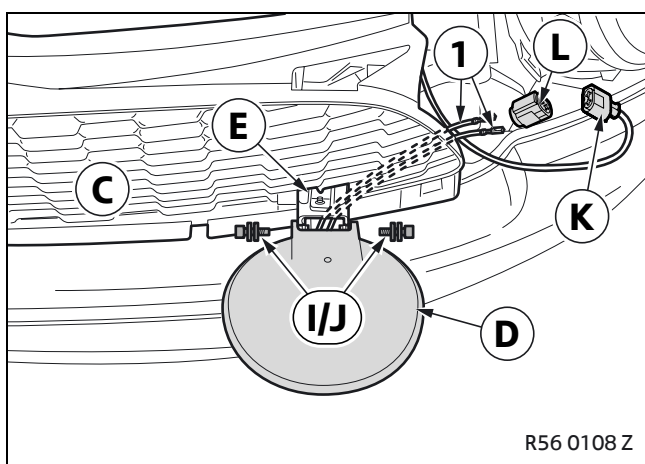

### All cars

Attach decorative strip to centre front grille C and loosely push into place.

Loosely attach left additional headlight D with bolts I and 2 washers J.

Route the connecting cable (1) under the holder E through the front centre grille C to the socket casing K.

Connect the cable (1) from the left additional headlight D as follows to the plug casing L (2-pin SW):

- Cable, VI/SW cable colour, to PIN 1
- Cable, BR cable colour, to PIN 2

Connect plug L to socket casing K.

Carry out same procedure for right-side headlight D.

Secure the front centre grille C.

## 8. Concluding work and coding

This retrofit system does not require coding.

- Connect the battery
- Conduct a brief test
- Conduct a function test
- Re-fit the car components as required
- Print out section 9 of these installation instructions and give it to the customer.

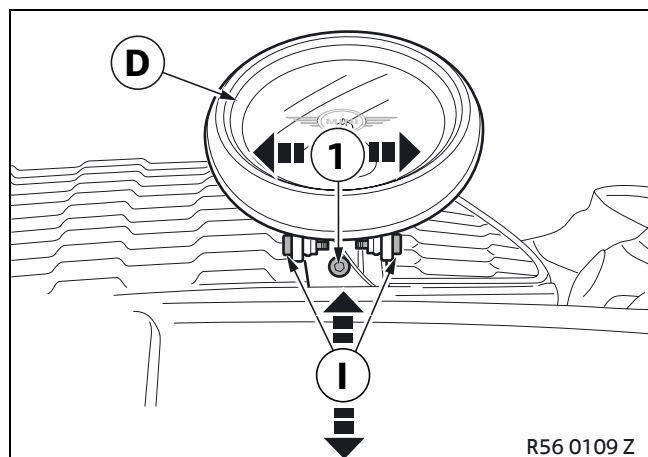

Adjust the additional headlight **D** as follows using headlight adjustment unit:

### Vertical adjustment

- Loosen screw (1) and make vertical adjustment

### Horizontal adjustment

- Loosen both screws **I** and make horizontal adjustment

- ▶ The tightening torque of the screw (2) is 12 Nm. ◀  
Tighten screws (1) and **I**.

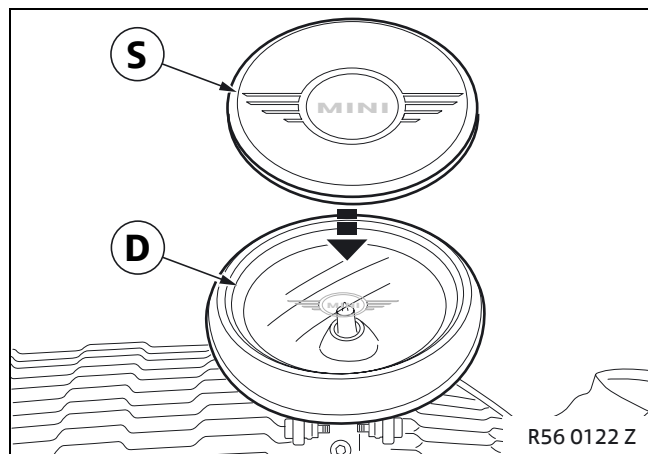

Fit headlight covers **S** to the additional headlights **D**.

- ⚠ Risk of damage by overheating. Never use the additional headlights **D** when the headlight covers **S** are fitted. ◀

## 9. Circuit diagram

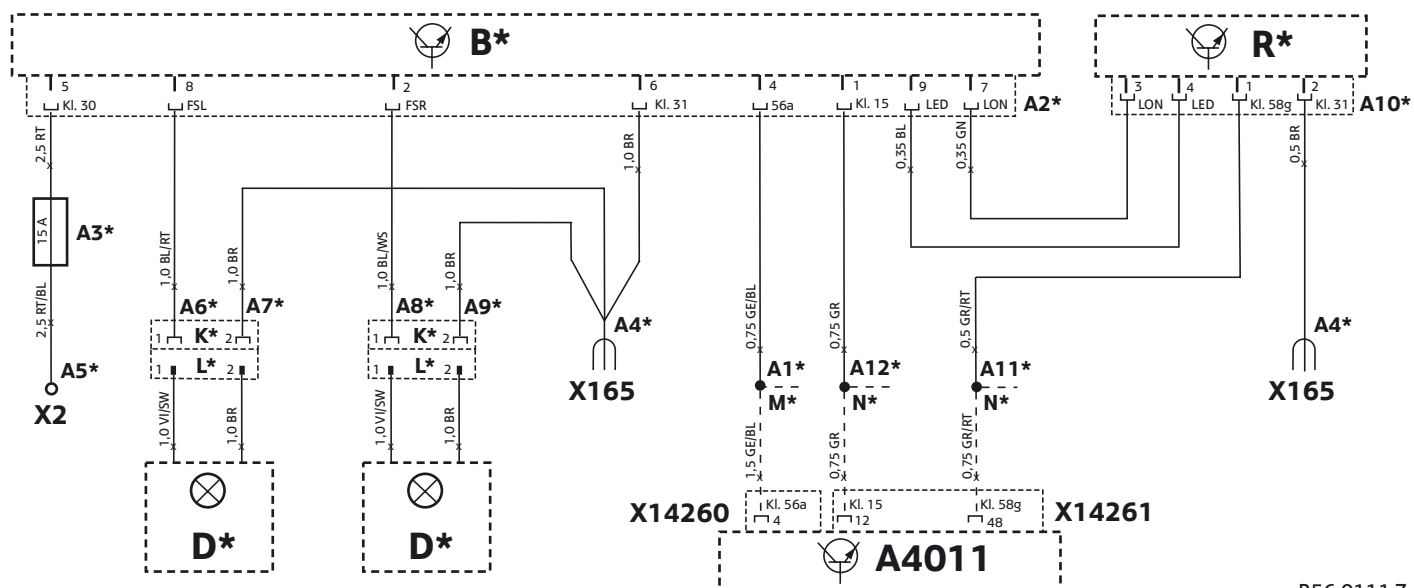

R56 0111 Z

### Legend

<b>A4011</b>	Footwell module
<b>A1*</b>	Socket contact
<b>A2*</b>	9-pin relay socket SW
<b>A3*</b>	Fuse holder
<b>A4*</b>	Eyelet M6
<b>A5*</b>	Eyelet M8
<b>A6*</b>	Socket contact
<b>A7*</b>	Socket contact
<b>A8*</b>	Socket contact
<b>A9*</b>	Socket contact
<b>A10*</b>	White 4-pin socket casing
<b>A11*</b>	Cable open
<b>A12*</b>	Cable open
<b>B*</b>	Control module
<b>D*</b>	Auxiliary headlights
<b>K*</b>	Black 2-pin socket casing
<b>L*</b>	Black 2-pin plug casing
<b>M*</b>	5-way miniature connector
<b>N*</b>	2-way miniature connector

## 9. Circuit diagram

### Legend

<b>R*</b>	Button
<b>X2</b>	Service point terminal 30 under fuse holder, engine compartment
<b>X165</b>	Service point terminal 31 under engine compartment fuse holder
<b>X14260</b>	51-pin SW/GR socket casing
<b>X14261</b>	Black 51-pin socket casing

All the designations marked with an asterisk (\*) apply only to these installation instructions or this circuit diagram.



### Cable colours

BL	Blue
BR	Brown
GE	Yellow
GR	Grey
SW	Black
RT	Red
VI	Violet
WS	White

## 10. Customer information for the additional headlights

Print out this customer information and give it to the customer.

### Pictograms

-  Denotes instructions that draw your attention to dangers.
-  Denotes instructions that draw your attention to special features.
-  Denotes the end of the instruction or other text.

### Operation of the additional headlights

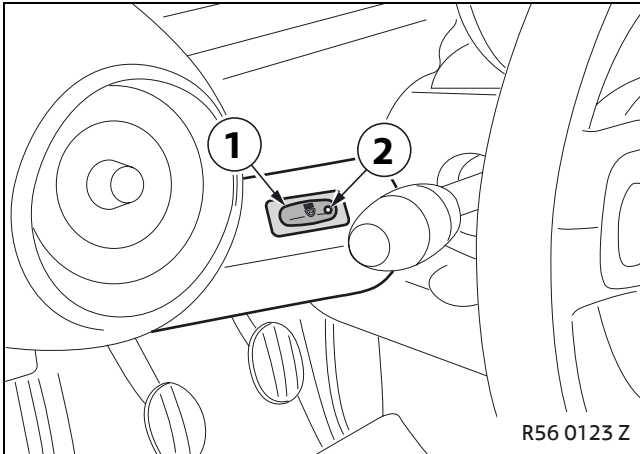

#### Switching on additional headlights automatically

 Once they have been activated, the additional headlights come on automatically with the headlight main beam or the headlamp flasher. As soon as you have switched the ignition off/on again, you must reactivate the additional headlights. ◀

- Switch on the ignition or start the engine
- Press the button (1) for activation

The additional headlights are now activated when the green light (2) in the pushbutton (1) is lit.

- Switch on the headlights or operate the headlamp flasher

The additional headlights now come on automatically with the headlight main beam or the headlamp flasher.

#### Switching on additional headlights manually:

- Switch on the ignition or start the engine
- Switch on the headlights or operate the headlamp flasher
- Press the button (1) to switch on lights

The additional headlights now come on automatically with the headlight main beam or the headlamp flasher.

#### Switching off additional headlights:

- Switch off main headlights or press the button (1) again.

 Pay attention to the relevant national and regional laws governing the use of additional headlights. For example, some states prohibit the simultaneous use of four lights, others completely ban their use on public highways and require that additional headlights are fitted with covers when not in use. ◀

 Risk of damage by overheating. Never use the additional headlights when the headlight covers are fitted. ◀

## 10. Customer information for the additional headlights

### Changing light bulbs

Lamps and lights are an essential element of vehicle safety. Appropriate care should therefore be applied in their use. If you are not familiar with such work, have it done by your local MINI Service.

 Bulbs required: **H3** (55 W). Never touch the glass of the bulbs directly with your fingers as even the slightest impurities will burn into the surface and reduce the life of the bulb. Always use a clean cloth, paper towel etc. or hold the base of the bulb. ◀

 Whenever working on the electrical systems of your car, switch off the appropriate circuit or disconnect the negative terminal of the battery, otherwise there is a risk of short circuits. Always read the instructions supplied by the bulb manufacturer in order to avoid injury or damage when replacing bulbs. ◀

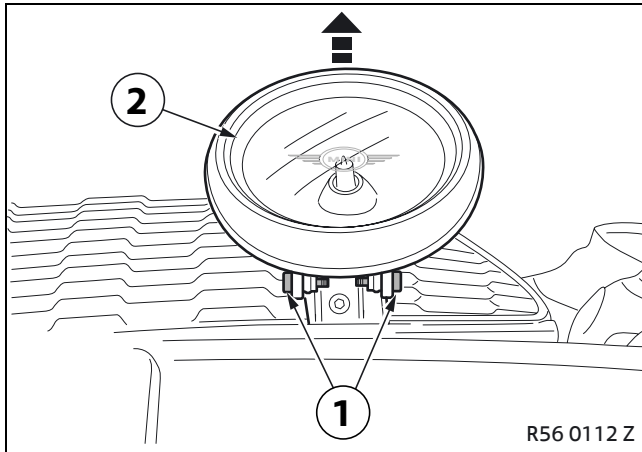

Undo both screws (1) and carefully pull the auxiliary headlight (2) forwards.

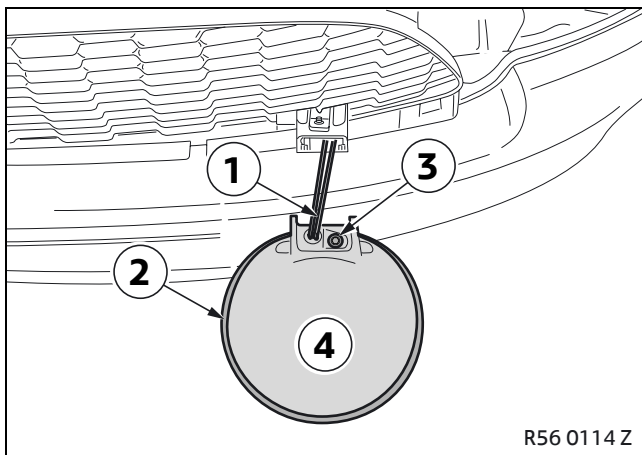

 To prevent damage to the cable (1), hold the additional headlight (2) in one hand. ◀

Undo and remove the Allen screw (3) and remove the casing (4).

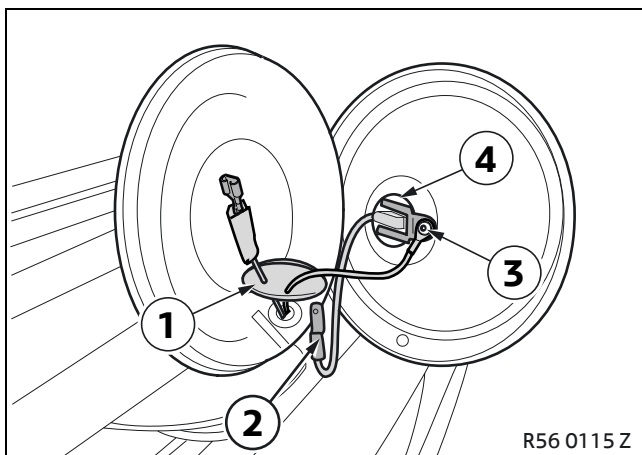

Pull off the rubber cover (1) and disconnect the plug (2).

Undo and remove the screw (3), and replace the bulb (4).

Re-assembly is carried out correspondingly in reverse order.

 The tightening torque of the screw (2) is 12 Nm. After changing the bulb, it is necessary to adjust the additional headlight. ◀

## 10. Customer information for the additional headlights

### Adjusting the additional headlights

 If you choose not to have your MINI Service adjust the headlights, you can perform this adjustment yourself without a headlight adjustment unit. The operations described refer to the left headlight, but the adjustment of the right headlight is performed in the same way.

To perform the adjustment, position your unladen vehicle on level ground and about 5 – 10 m away from, and at right angles to, a vertical wall, door etc. ◀

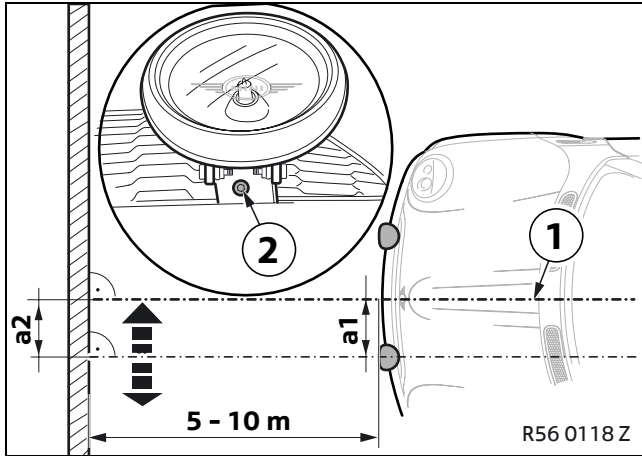

#### Checking vertical adjustment

- Measure the distance **a1** from the centre of the headlight to the longitudinal axis of the car (1).
- Measure the distance **a2** from the centre of the headlight to the longitudinal axis of the car (1).

If the distances **a1** and **a2** are not identical, carry out the vertical adjustment as follows:

#### Performing vertical adjustment

- Loosen the screw (2) and turn the additional headlight slightly to the right or left until the distances **a1** and **a2** are identical.

-  The tightening torque of the screw (2) is 12 Nm. ◀  
-Tighten the screw (2) with 12 Nm.

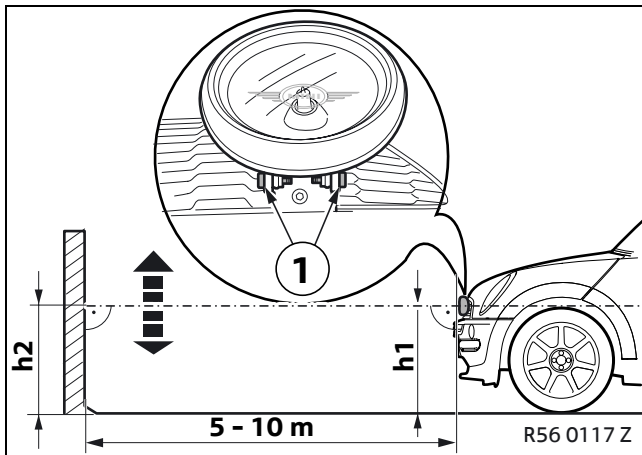

#### Checking horizontal adjustment

- Measure the height **h1** from the centre of the additional headlight to the ground.
- Measure the height **h2** from the centre of the light beam on the wall to the ground.

If the heights **h1** and **h2** are not identical, carry out the horizontal adjustment as follows:

#### Performing horizontal adjustment

- Loosen both screws (1) and raise or lower the additional headlights until the heights **h1** and **h2** are identical.

-  The tightening torque of the screw (2) is 12 Nm. ◀  
-Tighten the screws (1) with 12 Nm.

## 10. Customer information for the additional headlights

### Changing the fuse

**!** Whenever working on the electrical systems of your car, switch off the appropriate circuit or disconnect the negative terminal of the battery, otherwise there is a risk of short circuits.

Never try to repair a blown fuse or replace it with one of another colour or Amp rating, otherwise you could cause a fire in the car by overloading the electrical circuits. ◀

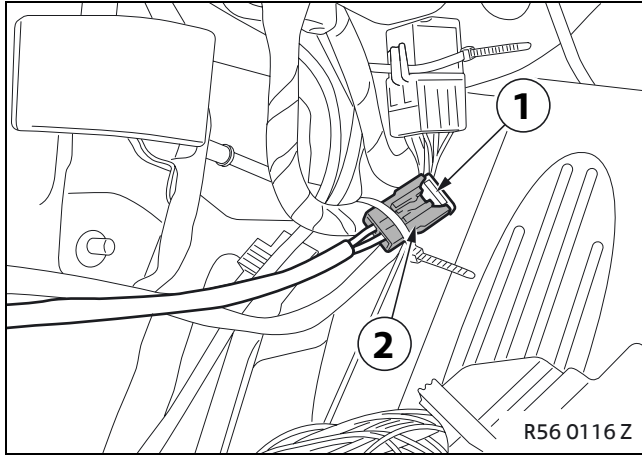

Fuse required (1): **15 A**

The fuse (1) for the additional headlights is located in the footwell on the driver's side behind the side trim.

Remove the fuse (1) from the fuse holder (2) and replace.

If the fuse blows again, take the car to your MINI Service to investigate the cause of the fault.

### Cleaning and maintenance

Use a soft damp cloth for cleaning the additional headlight and avoid using any abrasive or chemical cleaning agents.