

INSTALLATION INSTRUCTIONS FOR REVERSE MOUNT DUAL PEDAL ASSEMBLY

PART NUMBERS

340-11299 • 6.25:1 Brake and Clutch Pedal Ratio
340-13835 • 5.1:1 Brake and Clutch Pedal Ratio
340-13836 • 6.25:1 Brake/5.1:1 Clutch Pedal Ratio

**DISC BRAKES SHOULD ONLY BE INSTALLED BY SOMEONE
EXPERIENCED AND COMPETENT IN THE INSTALLATION AND
MAINTENANCE OF DISC BRAKES
READ ALL WARNINGS**

WARNING

IT IS THE RESPONSIBILITY OF THE PERSON INSTALLING ANY BRAKE COMPONENT OR KIT TO DETERMINE THE SUITABILITY OF THE COMPONENT OR KIT FOR THAT PARTICULAR APPLICATION. IF YOU ARE NOT SURE HOW TO SAFELY USE THIS BRAKE COMPONENT OR KIT, YOU SHOULD NOT INSTALL OR USE IT. DO NOT ASSUME ANYTHING. IMPROPERLY INSTALLED OR MAINTAINED BRAKES ARE DANGEROUS. IF YOU ARE NOT SURE, GET HELP OR RETURN THE PRODUCT. YOU MAY OBTAIN ADDITIONAL INFORMATION AND TECHNICAL SUPPORT BY CALLING WILWOOD AT (805) 388-1188, OR VISIT OUR WEB SITE AT WWW.WILWOOD.COM. USE OF WILWOOD TECHNICAL SUPPORT DOES NOT GUARANTEE PROPER INSTALLATION. **YOU**, OR THE PERSON WHO DOES THE INSTALLATION MUST KNOW HOW TO PROPERLY USE THIS PRODUCT. IT IS NOT POSSIBLE OVER THE PHONE TO UNDERSTAND OR FORESEE ALL THE ISSUES THAT MIGHT ARISE IN YOUR INSTALLATION.

RACING EQUIPMENT AND BRAKES MUST BE MAINTAINED AND SHOULD BE CHECKED REGULARLY FOR FATIGUE, DAMAGE, AND WEAR.



Need Additional Information?
Use Your SmartPhone and
Jump to Our Technical Tips
Section on Our Web Site.



WARNING

DO NOT OPERATE ANY VEHICLE ON UNTESTED BRAKES!
SEE MINIMUM TEST PROCEDURE WITHIN

ALWAYS UTILIZE SAFETY RESTRAINT SYSTEMS AND ALL OTHER AVAILABLE SAFETY EQUIPMENT WHILE OPERATING THE VEHICLE

IMPORTANT • READ THE DISCLAIMER OF WARRANTY INCLUDED IN THE KIT

NOTE: Some cleaners may stain or remove the finish on brake system components. Test the cleaner on a hidden portion of the component before general use.

Photographic Tip

Important and highly recommended: Take photos of brake system before disassembly and during the disassembly process. In the event, trouble-shooting photos can be life savers. Many vehicles have undocumented variations, photos will make it much simpler for Wilwood to assist you if you have a problem.

General Information and Assembly Instructions

Installation of this component should **ONLY** be performed by persons experienced in the installation and proper operation of disc brake systems. Before assembly begins, familiarize yourself with the following procedure to ensure a trouble-free installation.

Features:

- Adjustable pedal foot pads
- Lightweight construction.
- High strength computer design.
- Includes brake balance bar and clevis.
- High strength steel master cylinder mounting studs.
- Easy mounting location.
- Stainless steel foot pads.
- Wilwood's own Platinum-E coat finish.
- Finest quality hardware.
- Keeps master cylinder away from heat source.
- Use with Wilwood compact, high volume, or combination master cylinders.

Pedal Shown with Optional Master Cylinders



Installation Instructions:

Wilwood's reverse mount dual pedal assembly can be mounted in two methods: (1) Using the four outboard tab mounting holes, attach the pedal assembly to two sturdy beams or plates with four 5/16 inch bolts. (2) Utilize the four 1/4-20 top mount standoffs in addition to two or four 5/16 inch outboard tab mounts. **DO NOT** use the four top mount standoffs by themselves. Pedal assembly must be rigidly attached to frame and not deflect under heavy pedal forces. **NOTE:** Pedals must be free from obstructions over their entire range of motion. Allow enough space so balance bar adjustments can be made and master cylinders are accessible.

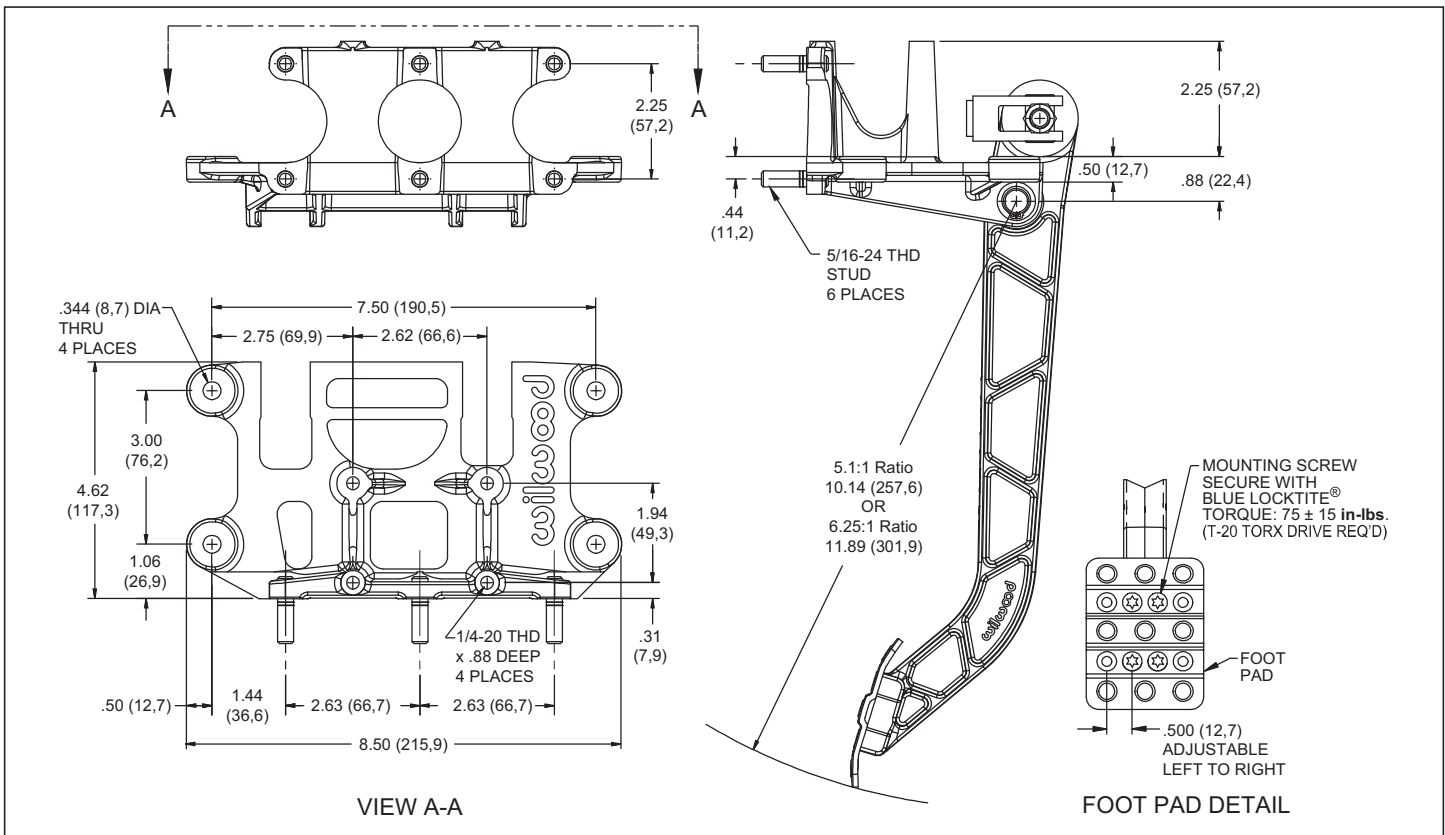

Reverse Mount Dual Pedal Assembly, Physical Dimensions

Additional Information and Recommendations

Additional Information and Recommendations:

- The pedal assembly uses standard racing master cylinder mounting patterns. Wilwood's compact, high volume, and combination remote master cylinders mount directly to the pedal assembly, as do most other high performance master cylinders. All master cylinder mounting hardware is included with the pedal assembly. Master cylinder flange should mount flush to pedal assembly and be held in place with enclosed washers and locknuts. The clevis on each pedal has a 5/16-24 thread. Make sure to use a jam nut on the master cylinder pushrod when threaded into clevis and check that pushrod is allowed to fully retract when pedal is released.
- Wilwood Hi-Temp° 570 Racing Brake Fluid (6 pack P/N 290-2210) is recommended for race cars and high performance vehicles where brake temperatures exceed normal operating conditions, or use Wilwood EXP 600 Plus Super Hi-Temp (6 pack P/N 290-8478) for extreme conditions. **NOTE: Silicone DOT 5 brake fluid is NOT recommended for racing or performance driving.**
- Adjust the balance bar so that the appropriate front to rear brake balance is achieved, reference our data sheet DS-252 (available at www.wilwood.com/PDF/DataSheets/ds252.pdf).
- If after following the instructions, you still have difficulty in assembling your Wilwood reverse mount dual pedal assembly, consult your local chassis builder, or retailer where the component was purchased for further assistance.

Brake Testing

WARNING • DO NOT DRIVE ON UNTESTED BRAKES BRAKES MUST BE TESTED AFTER INSTALLATION OR MAINTENANCE MINIMUM TEST PROCEDURE

- Make sure pedal is firm: Hold firm pressure on pedal for several minutes, it should remain in position without sinking. If pedal sinks toward floor, check system for fluid leaks. DO NOT drive vehicle if pedal does not stay firm or can be pushed to the floor with normal pressure.
- At very low speed (2-5 mph) apply brakes hard several times while turning steering from full left to full right, repeat several times. Remove the wheels and check that components are not touching, rubbing, or leaking.
- Carefully examine all brake components, brake lines, and fittings for leaks and interference.
- Make sure there is no interference with wheels or suspension components.
- Drive vehicle at low speed (15-20 mph) making moderate and hard stops. Brakes should feel normal and positive. Again check for leaks and interference.
- Always test vehicle in a safe place where there is no danger to (or from) other people or vehicles.
- Always wear seat belts and make use of all safety equipment.

Pad and Rotor Bedding

BEDDING STEPS FOR NEW PADS AND ROTORS – ALL COMPOUNDS

Once the brake system has been tested and determined safe to operate the vehicle, follow these steps for the bedding of all new pad materials and rotors. These procedures should only be performed on a race track, or other safe location where you can safely and legally obtain speeds up to 65 MPH, while also being able to rapidly decelerate.

- Begin with a series of light decelerations to gradually build some heat in the brakes. Use an on-and-off the pedal technique by applying the brakes for 3-5 seconds, and then allow them to fully release for a period roughly twice as long as the deceleration cycle. If you use a 5 count during the deceleration interval, use a 10 count during the release to allow the heat to sink into the pads and rotors.
- After several cycles of light stops to begin warming the brakes, proceed with a series of medium to firm deceleration stops to continue raising the temperature level in the brakes.
- Finish the bedding cycle with a series of 8-10 hard decelerations from 55-65 MPH down to 25 MPH while allowing a proportionate release and heat-sinking interval between each stop. The pads should now be providing positive and consistent response.
- If any amount of brake fade is observed during the bed-in cycle, immediately begin the cool down cycle.
- Drive at a moderate cruising speed, with the least amount of brake contact possible, until most of the heat has dissipated from the brakes. Avoid sitting stopped with the brake pedal depressed to hold the car in place during this time. Park the vehicle and allow the brakes to cool to ambient air temperature.

COMPETITION VEHICLES

- If your race car is equipped with brake cooling ducts, blocking them will allow the pads and rotors to warm up quicker and speed up the bedding process.
- Temperature indicating paint on the rotor and pad edges can provide valuable data regarding observed temperatures during the bedding process and subsequent on-track sessions. This information can be highly beneficial when evaluating pad compounds and cooling efficiencies.

POST-BEDDING INSPECTION – ALL VEHICLES

- After the bedding cycle, the rotors should exhibit a uniformly burnished finish across the entire contact face. Any surface irregularities that appear as smearing or splotching on the rotor faces can be an indication that the brakes were brought up to temperature too quickly during the bedding cycle. If the smear doesn't blend away after the next run-in cycle, or if chatter under braking results, sanding or resurfacing the rotors will be required to restore a uniform surface for pad contact.

PRE-RACE WARM UP

- Always make every effort to get heat into the brakes prior to each event. Use an on-and-off the pedal practice to warm the brakes during the trip to the staging zone, during parade laps before the flag drops, and every other opportunity in an effort to build heat in the pads and rotors. This will help to ensure best consistency, performance, and durability from your brakes.

DYNO BEDDED COMPETITION PADS AND ROTORS

- Getting track time for a proper pad and rotor bedding session can be difficult. Wilwood offers factory dyno-bedded pads and rotors on many of our popular competition pads and **Spec 37** GT series rotors. Dyno-bedded parts are ready to race on their first warm up cycle. This can save valuable time and effort when on-track time is either too valuable or not available at all, Dyno-bedding assures that your pads and rotors have been properly run-in and are ready to go. Contact your dealer or the factory for more information on Wilwood Dyno-Bedding services.

NOTE:

NEVER allow the contact surfaces of the pads or rotors to be contaminated with brake fluid. Always use a catch bottle with a hose to prevent fluid spill during all brake bleeding procedures.