



TYPHOON INTAKE SYSTEMS

NOT LEGAL FOR SALE OR USE ON ANY POLLUTION CONTROLLED MOTOR VEHICLE IN CALIFORNIA OR STATES ADOPTING CALIFORNIA EMISSION PROCEDURES.

See knfilters.com for CARB status on each part for a specific vehicle

INSTALLATION INSTRUCTIONS

69-2026TTK

MINI

2014-16 Cooper S

L4-2.0L Turbo

2014-16 Cooper

L3-1.5L Turbo

TOOLS NEEDED:

- ratchet
- extension
- 10mm socket
- 13mm socket
- flat blade screw driver
- 2.5mm allen key

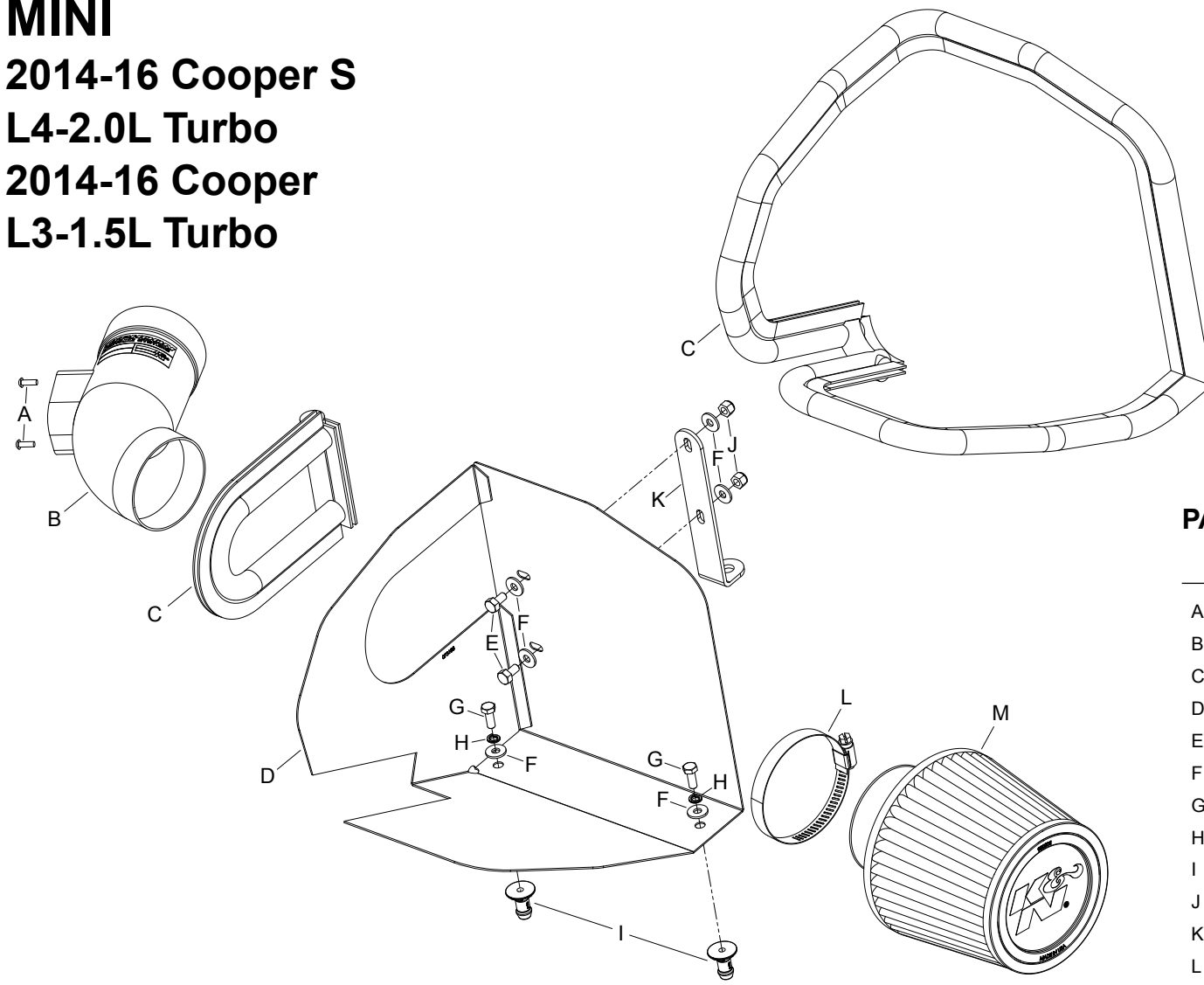

PARTS LIST:

	Description	Qty.	Part #
A	screw; m4- .7 x 12, button head	2	07726
B	intake tube	1	27634
C	edge trim (75")	1	102460
D	heat shield	1	073188
E	bolt; m6 x 1.00 x 12mm, ss	2	07727
F	washer; 6mm flat, ss	6	08269
G	bolt; 6mm-1.00 x 16mm, ss	2	07812
H	washer, m6 split lock zinc	2	1-3025
I	mount, plastic airbox, nylon	2	8-186-1
J	nut; 6mm nylock, hexhead, ss	2	07512
K	bracket; I, 69-4524, stl, tb/pc	1	083172
L	hose clamp # 52	1	08610
M	air filter	1	RU-5176

NOTE: FAILURE TO FOLLOW INSTALLATION INSTRUCTIONS AND NOT USING THE PROVIDED HARDWARE MAY DAMAGE THE INTAKE TUBE, THROTTLE BODY AND ENGINE.

TO START:

1. Turn off the ignition and disconnect the negative battery cable.
NOTE: Disconnecting the negative battery cable erases pre-programmed electronic memories. Write down all memory settings before disconnecting the negative battery cable. Some radios will require an anti-theft code to be entered after the battery is reconnected. The anti-theft code is typically supplied with your owner's manual. In the event your vehicles anti-theft code cannot be recovered, contact an authorized dealership to obtain your vehicles anti-theft code.



2. Disconnect the mass air sensor electrical connection.

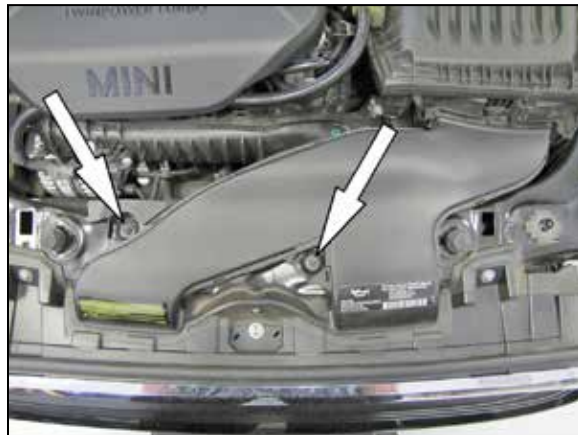

3. Remove the two nuts that secure the fresh air intake scoop and then remove the scoop from the vehicle.



4. Remove the bolt shown that secures the air filter housing to the core support.



5. Loosen the hose clamp securing the intake tube to the air filter housing and unhook the ground cable from the air filter housing, then lift up the air filter housing and remove it from vehicle.
NOTE: K&N Engineering, Inc., recommends that customers do not discard factory air intake.

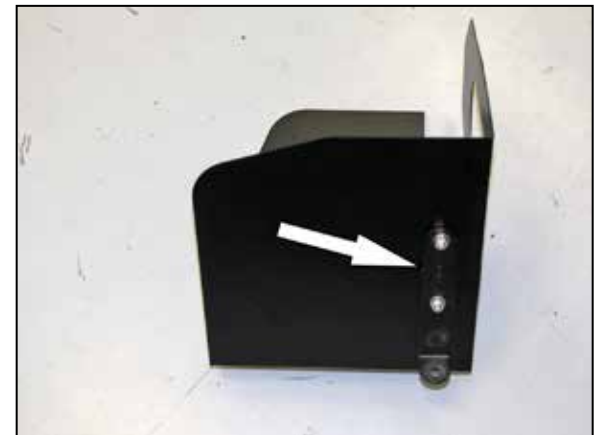

6. Install the heat shield mounting bracket (083172) onto the heat shield using the provided hardware.

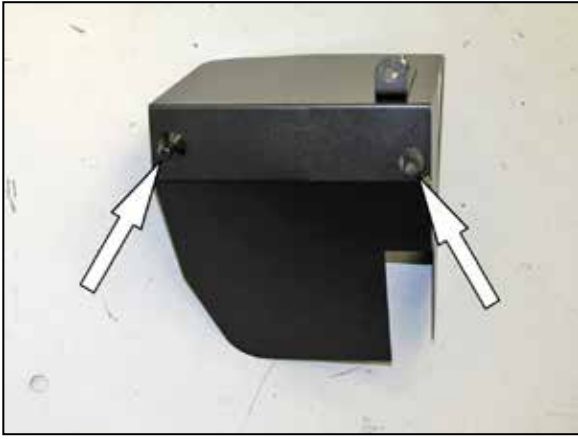

7. Install the two provided mounting studs onto the heat shield as shown.

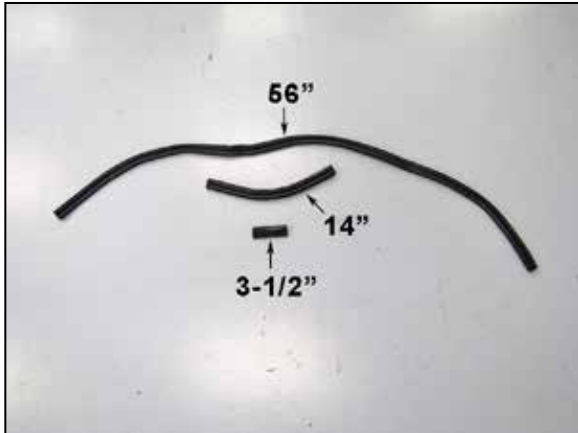

8. Cut the provided edge trim into three sections as shown. One section will be 56" long, one section will be 14" long, and one section will be 3-1/2" long.



9. Install the 56" edge trim around the heat shield as shown.



10. Install the 3-1/2" and 14" edge trim into the hole of the heat shield as shown.



11. Remove the battery cover bolt shown.
NOTE: This bolt will be reused in the next step.



12. Install the heat shield into the vehicle so the mounting studs engage the mounting grommets and then secure the heat shield with the battery cover bolt removed in the previous step.



13. Remove the two bolts that secure the mass air sensor to the factory air filter housing and then remove the mass air sensor.



14. Install the mass air sensor into the K&N® intake tube and secure with the provided hardware.



15. Install the K&N® intake tube into the heat shield and turbo inlet hose and then secure the tube with the provided hose clamp.



16. Install the K&N® air filter onto the intake tube and secure with the provided hose clamp. Adjust the tube and filter position for best fit.



17. Reconnect the mass air sensor electrical connection.



18. Reinstall the fresh air intake scoop and secure with the factory hardware.

19. Reconnect the vehicle's negative battery cable. Double check to make sure everything is tight and properly positioned before starting the vehicle.

20. It will be necessary for all K&N® high flow intake systems to be checked periodically for realignment, clearance and tightening of all connections. Failure to follow the above instructions or proper maintenance may void warranty.

ROAD TESTING:

1. Start the engine with the transmission in neutral or park, and the parking brake engaged. Listen for air leaks or odd noises. For air leaks secure hoses and connections. For odd noises, find cause and repair before proceeding. This kit will function identically to the factory system except for being louder and much more responsive.

2. Test drive the vehicle. Listen for odd noises or rattles and fix as necessary.

3. If road test is fine, you can now enjoy the added power and performance from your kit.

4. K&N Engineering, Inc., requires cleaning the intake system's air filter element every 100,000 miles. When used in dusty or off-road environments, our filters will require cleaning more often. We recommend that you visually inspect your filter once every 25,000 miles to determine if the screen is still visible. When the screen is no longer visible some place on the filter element, it is time to clean it. To clean and re-oil, purchase our filter Recharger® service kit, part number 99-5050 or 99-5000 and follow the easy instructions.

NOT LEGAL FOR SALE OR USE ON ANY POLLUTION CONTROLLED MOTOR VEHICLE IN CALIFORNIA OR STATES ADOPTING CALIFORNIA EMISSION PROCEDURES.

See knfilters.com for CARB status on each part for a specific vehicle